

Prospects of the sPHENIX Cold-QCD Physics Program at RHIC

Ming X. Liu

Los Alamos National Laboratory
(for the sPHENIX Collaboration)

The 11th Circum-Pan-Pacific Symposium on High Energy Spin Physics
August 27-30, 2019, Miyazaki, Japan



Outline

- sPHENIX physics and detectors
 - Quark-Gluon-Plasma
- A new Cold-QCD physics opportunity
 - Nucleon spin, TMD
 - Small-x, nuclear PDF
 - Forward upgrade
- Outlook
 - Forward upgrade
 - EIC

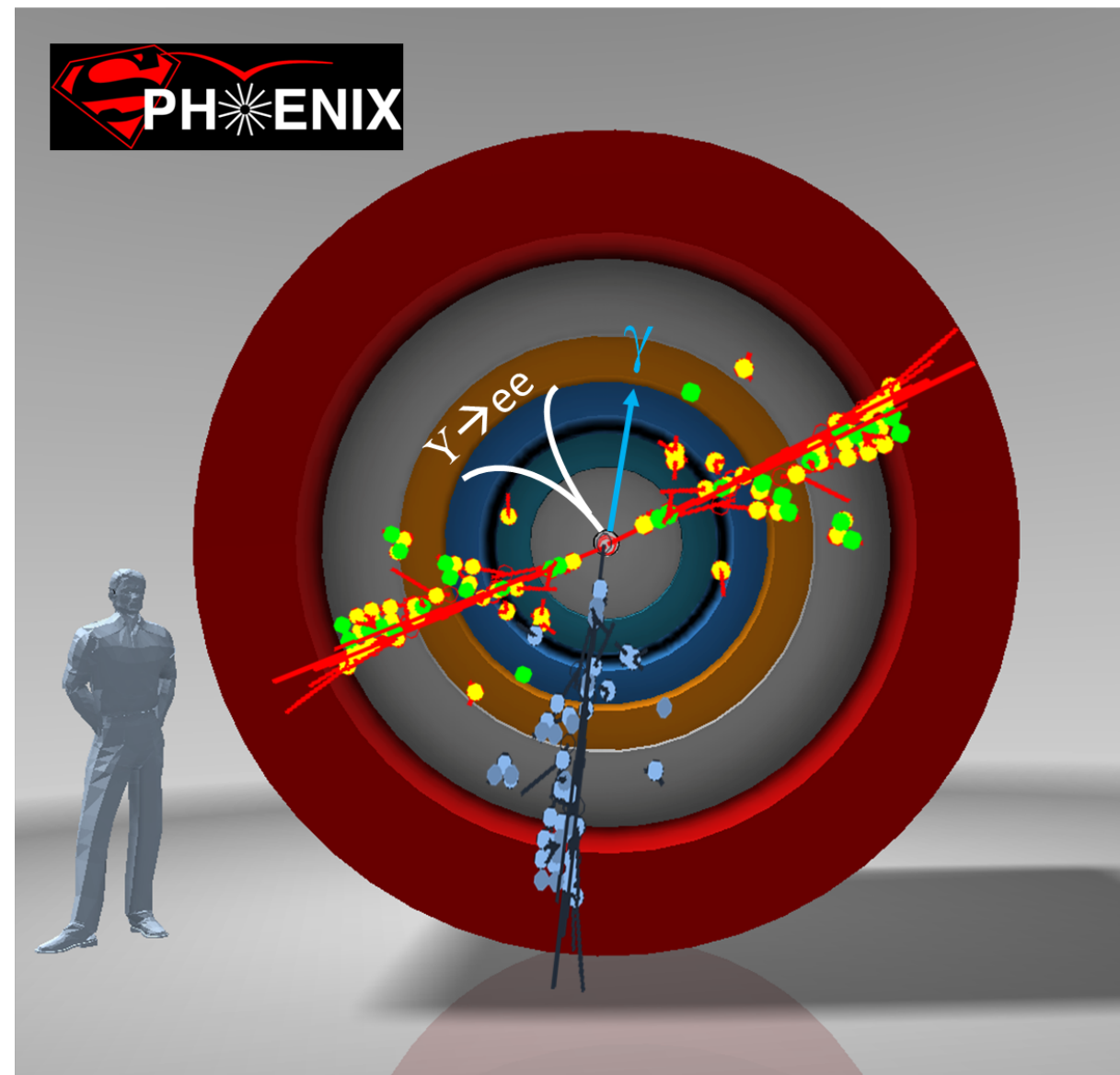

US Nuclear Physics Long Range Plan (2015)



sPHENIX – to understand “Inner Workings of QGP”

REACHING FOR THE HORIZON



The Site of the Wright Brothers' First Airplane Flight



The 2015
LONG RANGE PLAN
for NUCLEAR SCIENCE

"To understand the workings of the QGP, there is no substitute for microscopy. We know that if we had a sufficiently powerful microscope that could resolve the structure of QGP on length scales, say a thousand times smaller than the size of a proton, what we would see are quarks and gluons interacting only weakly with each other. **The grand challenge for this field in the decade to come is to understand how these quarks and gluons conspire to form a nearly perfect liquid.**"

sPHENIX Upgrade at RHIC

the next generation Heavy Ion Physics experiment in the US



RHIC

Φ 1.2km

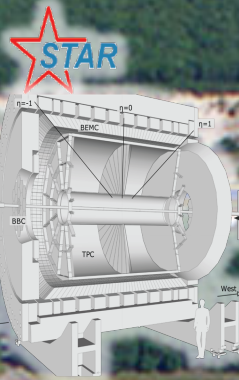

LINAC

EBIS

NSRL

BOOSTER

AGS

TANDEMS

Evolution of the PHENIX Interaction Region at RHIC

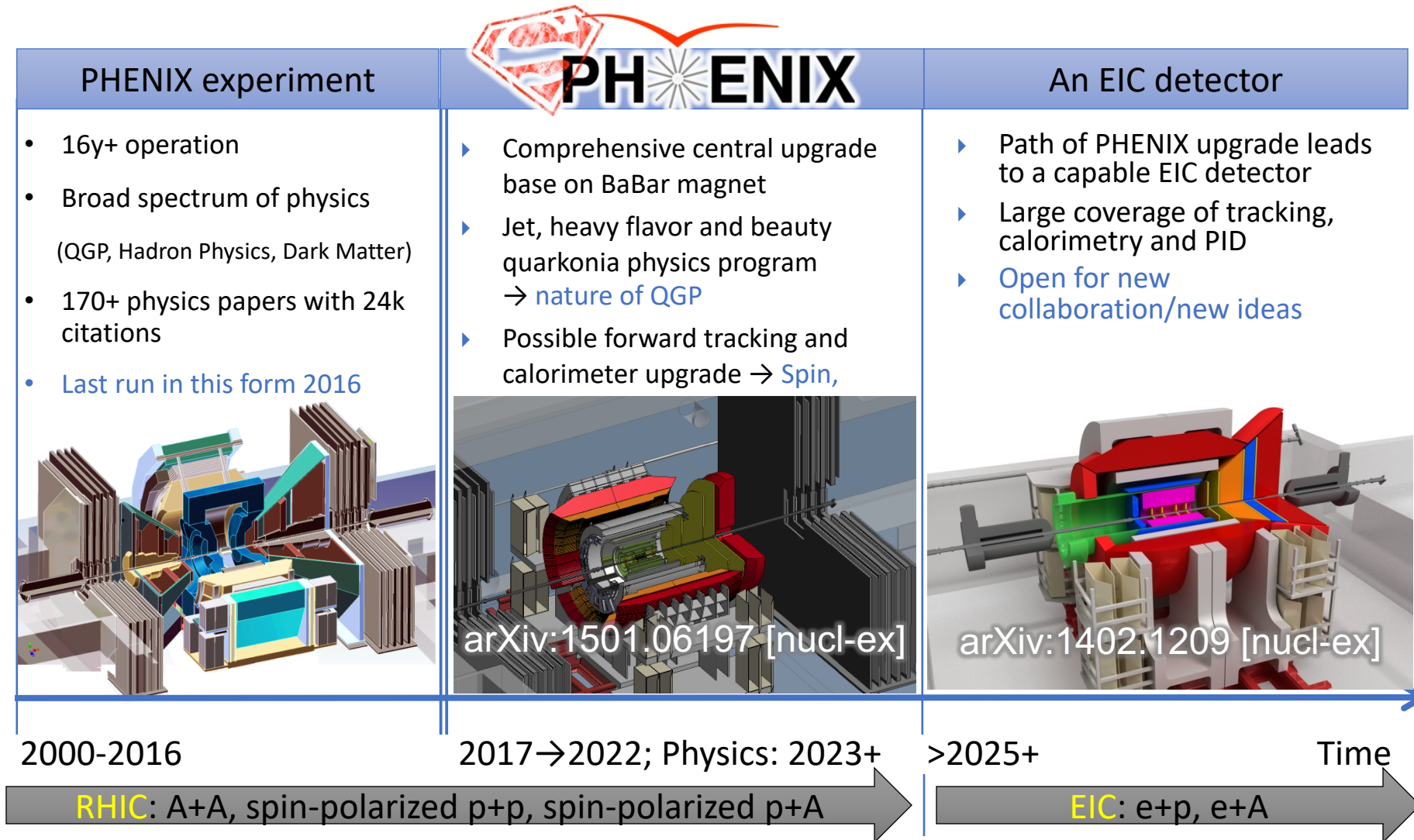

The sPHENIX Detectors

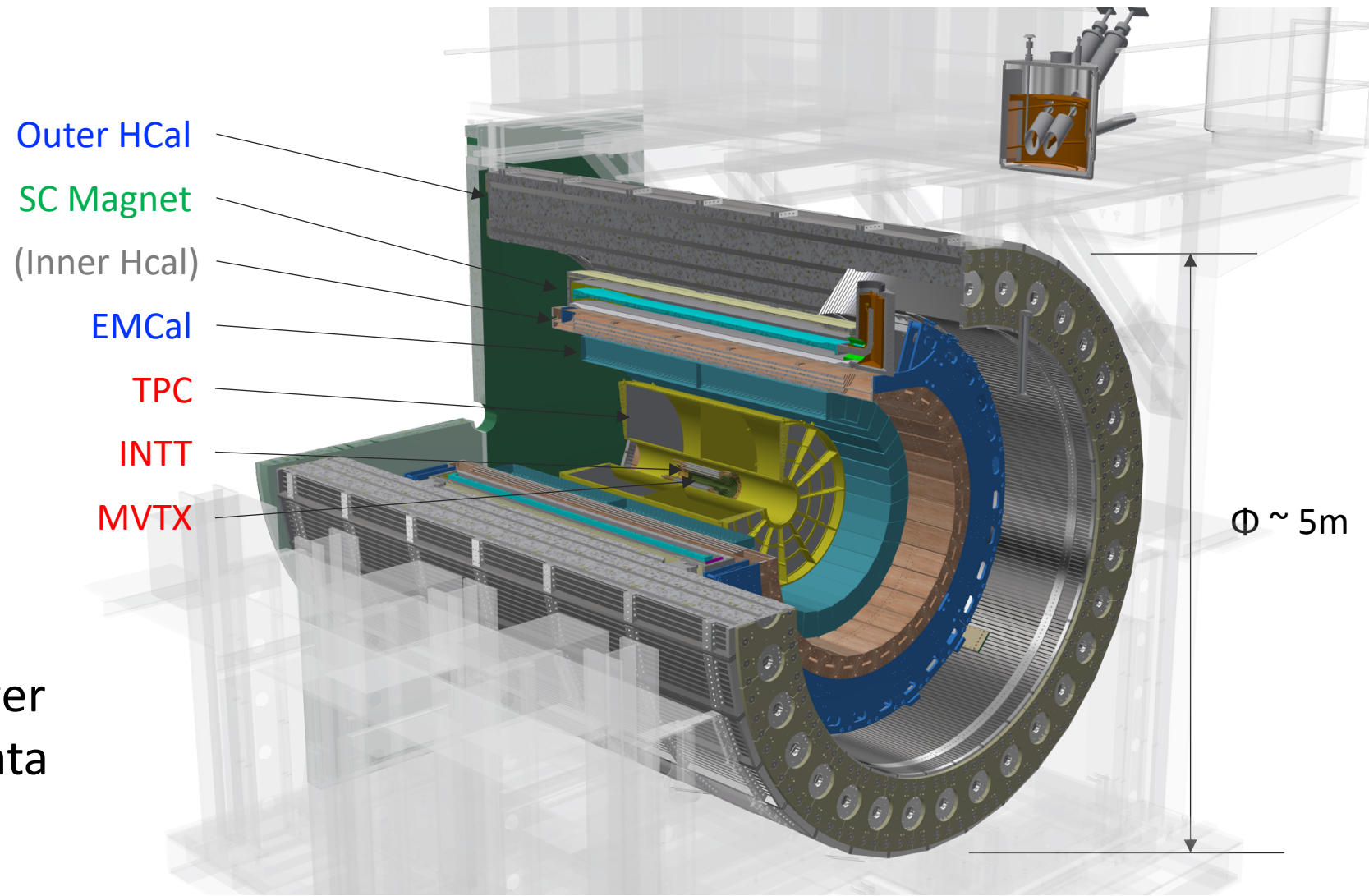

- $|\eta| < 1.1$
- B: 1.4 T
- 15 kHz trigger
- >10 GB/s data

Probing the Inner Workings of QGP in sPHENIX

- Key Capabilities

Jet structure

vary momentum/angular scale
of probe

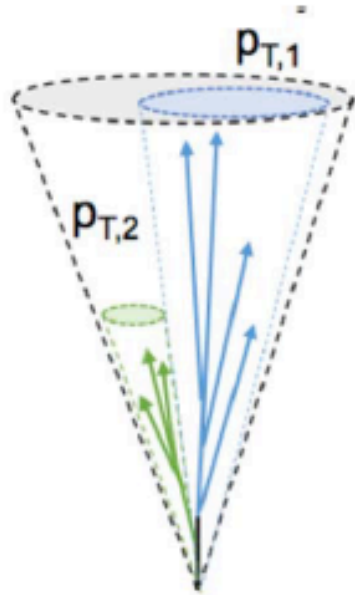

Quarkonium spectroscopy

vary size of probe

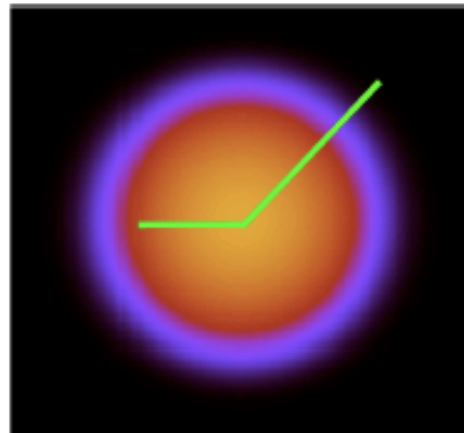
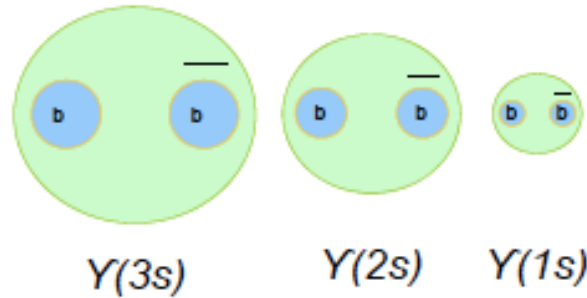

Parton energy loss

vary mass/momentum of probe

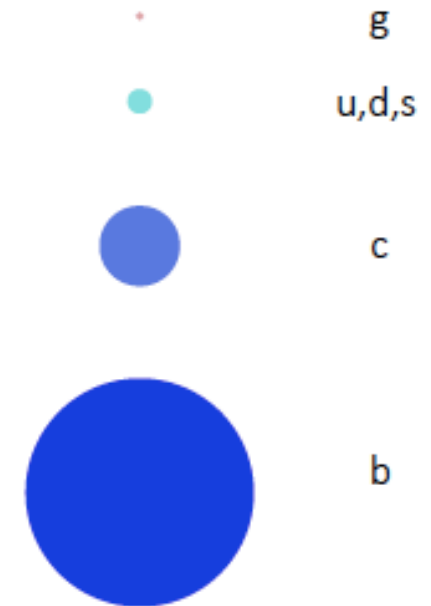

sPHENIX Detector Sub-Systems

Tracker

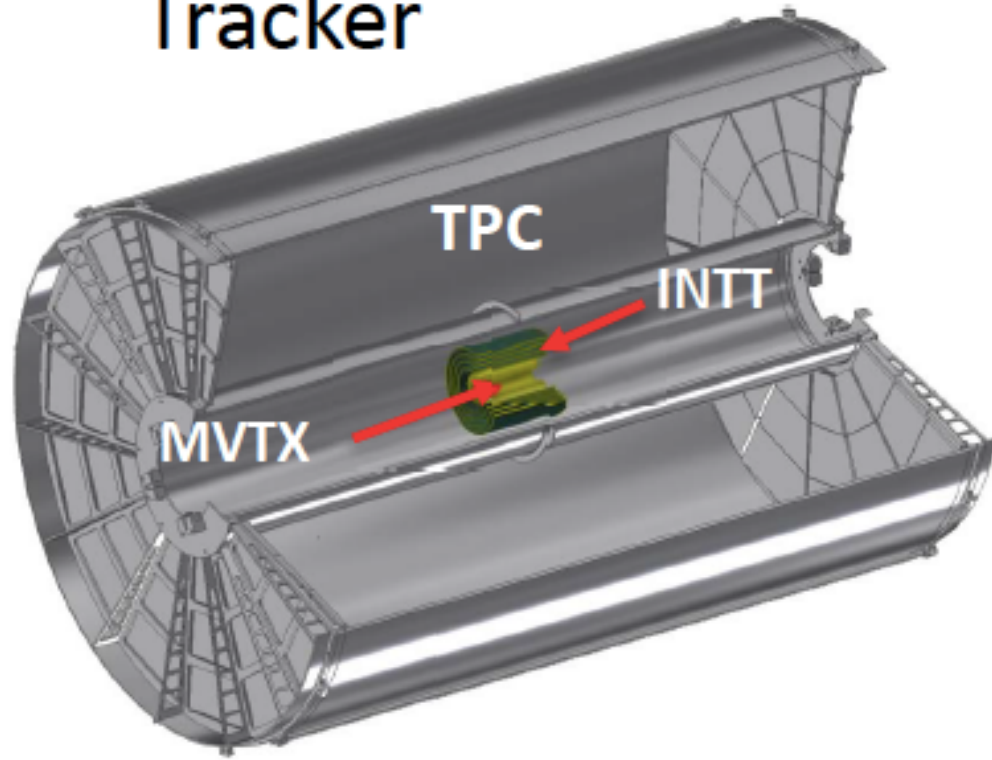

Continuous readout TPC
Si strip intermediate tracker
3-layer MAPS-based μ vertex

Calorimeter stack

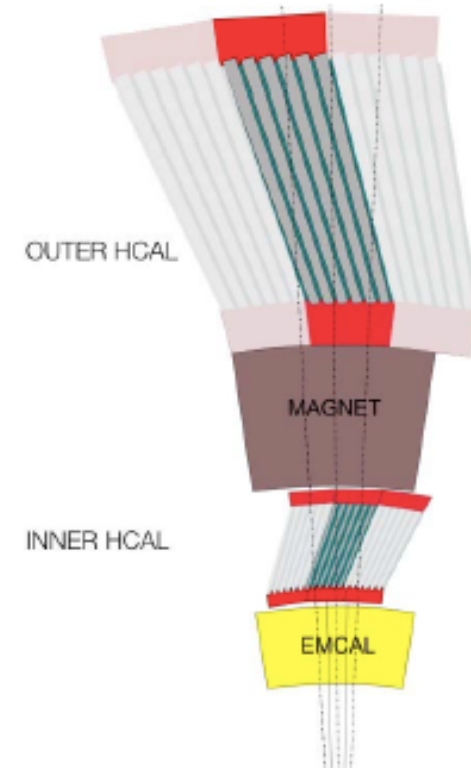

Tungsten/SciFi EMCal
Steel/plastic scintillator HCAL
SiPM readout

Detector Performance: Tracking and Jets

GEANT simulations verified with test beam data

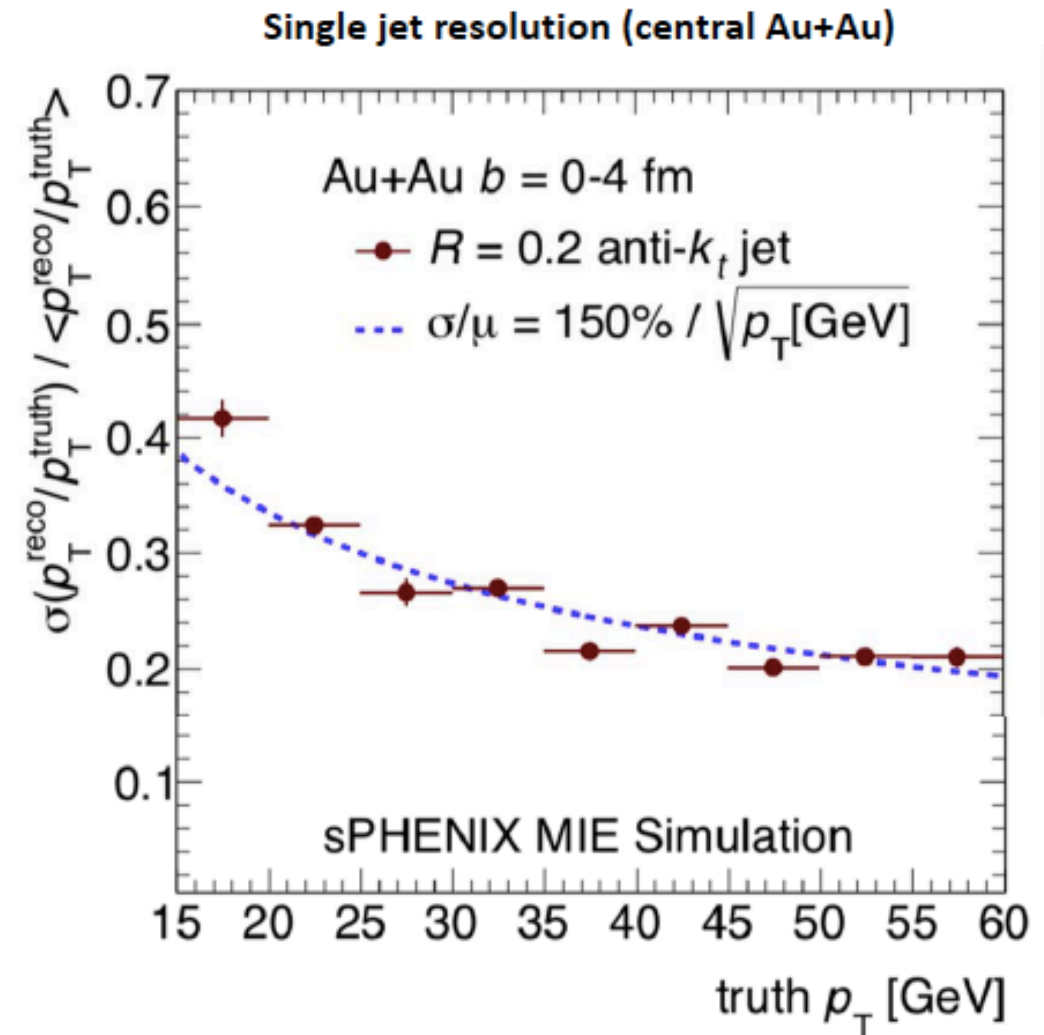
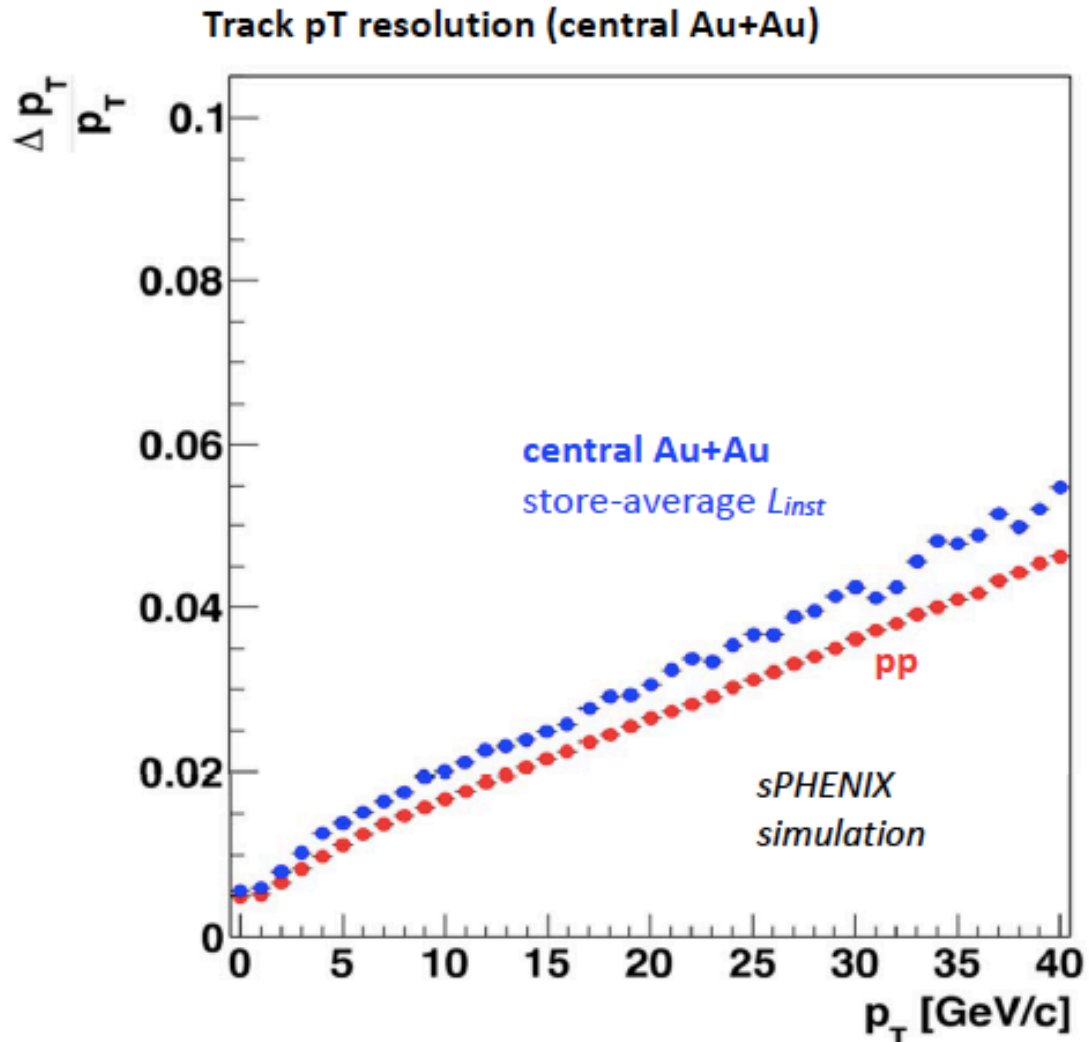

Calorimeters Beam Tests



February 2014
Proof of principle

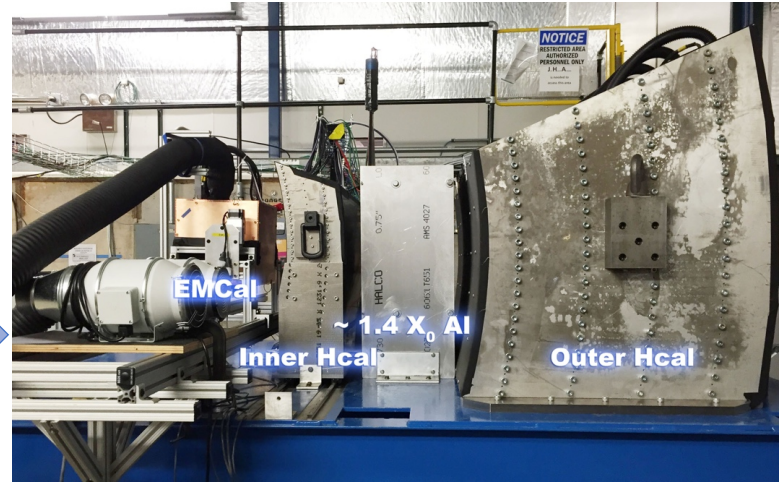

February 2016: $\eta \sim 0$ prototype

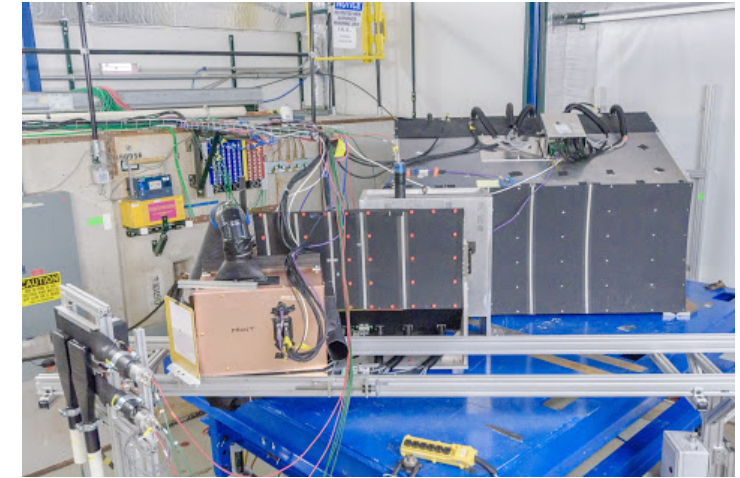

February 2017: $\eta \sim 0.9$ prototype

Electron
Energy resolution
arXiv:1704.01461

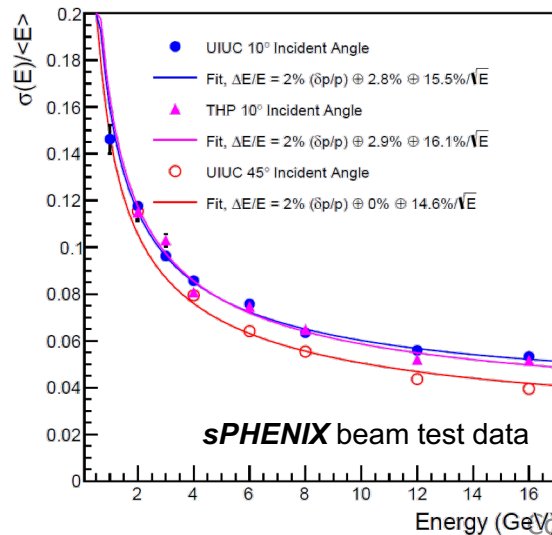

Pion
Energy resolution
arXiv:1704.01461

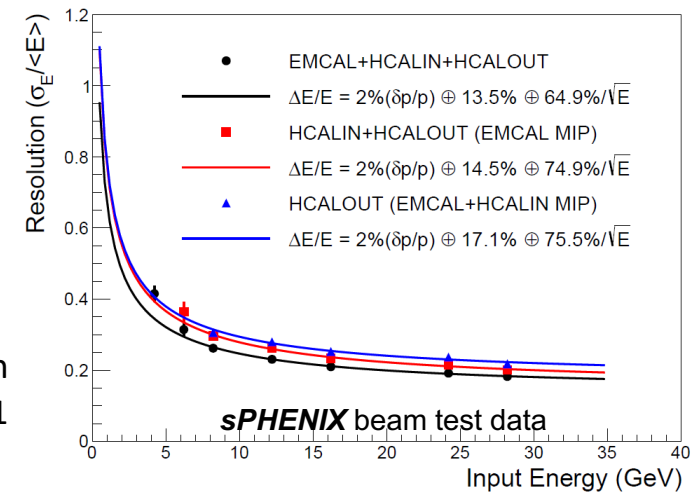

Monolithic-Active-Pixel-Sensor based Precision Vertex Detector

-- for Open Heavy Quark Measurements



Stave layout beam view

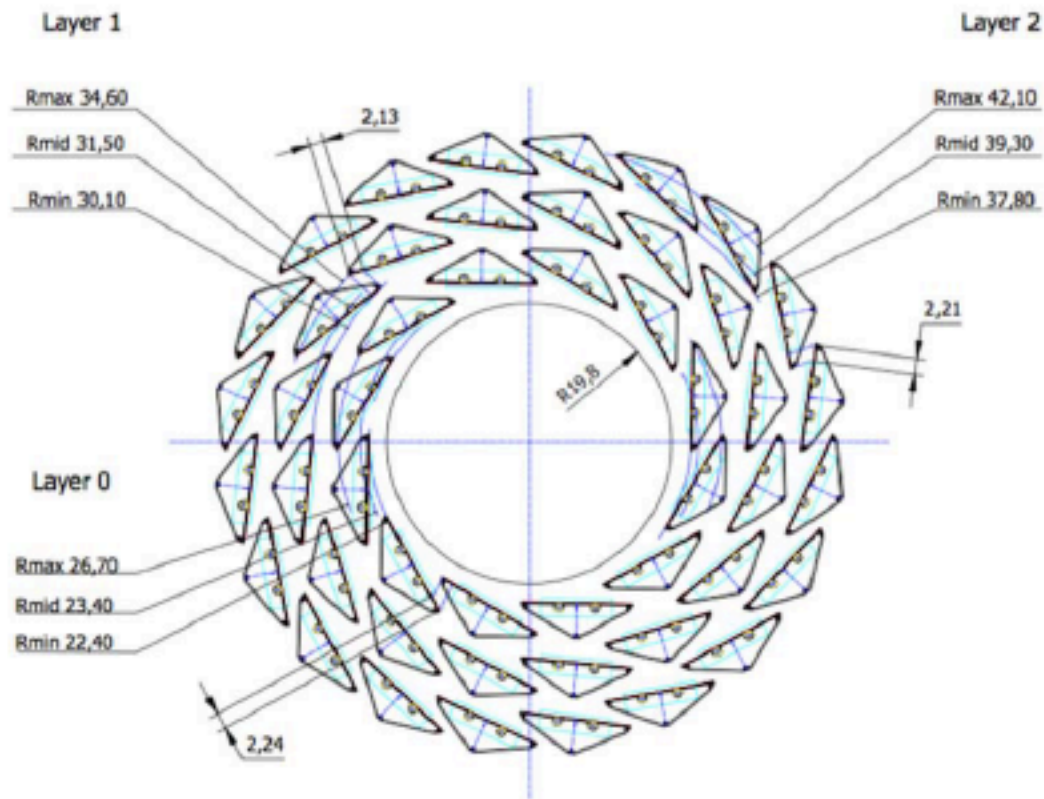

MVTX based on copy of ALICE staves with support structure modified for sPHENIX

MVTX spatial resolution

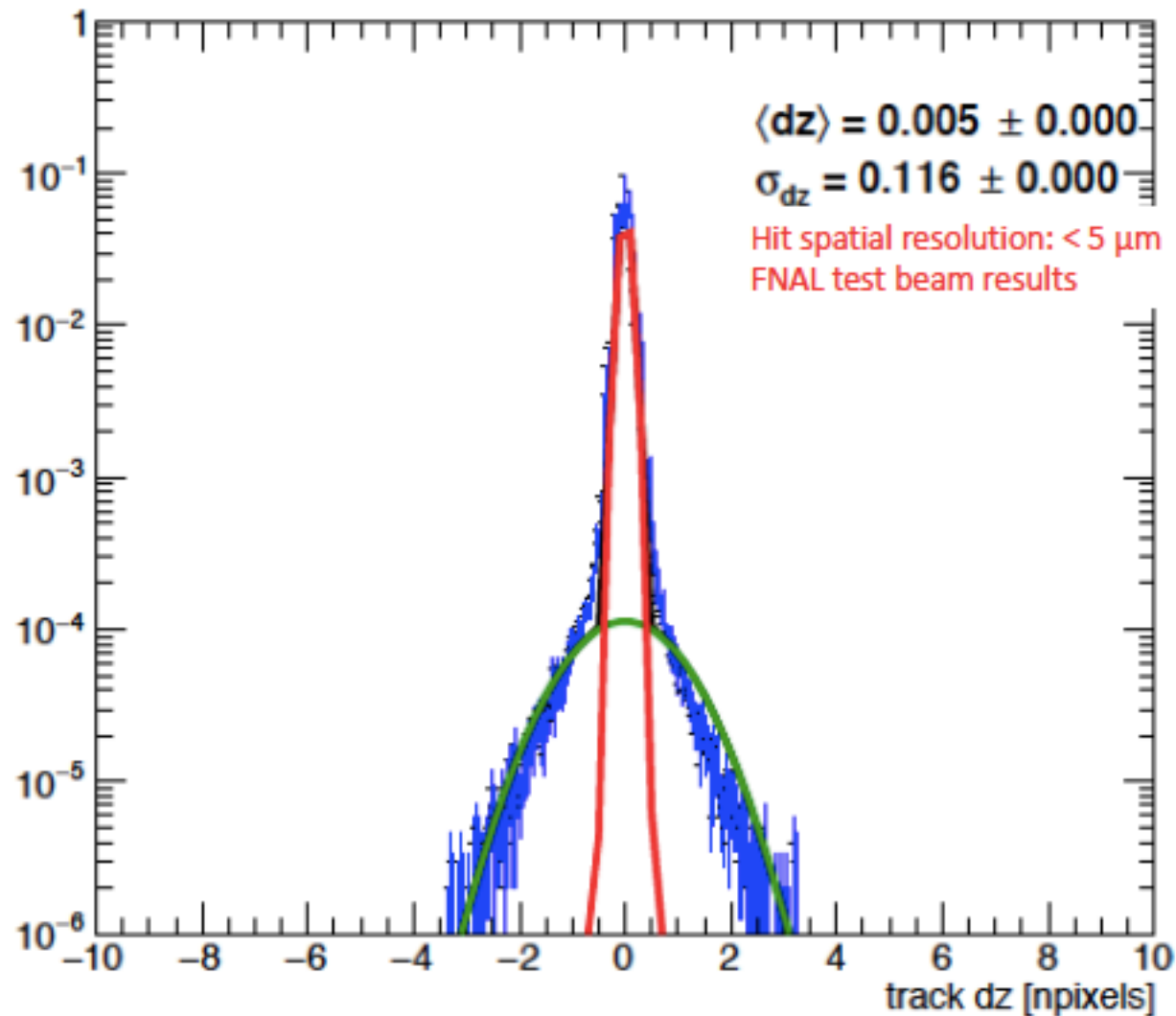

Evolving sPHENIX Run Plan

Champaign -2, Champaign-1

Year	Species	Energy [GeV]	Phys. Wks	Rec. Lum.	Samp. Lum.	Samp. Lum. All-Z
Year-1	Au+Au	200	16.0	7 nb ⁻¹	8.7 nb ⁻¹	34 nb ⁻¹
Year-2	p+p	200	11.5	—	48 pb ⁻¹	267 pb ⁻¹
Year-2	p+Au	200	11.5	—	0.33 pb ⁻¹	1.46 pb ⁻¹
Year-3	Au+Au	200	23.5	14 nb ⁻¹	26 nb ⁻¹	88 nb ⁻¹
Year-4	p+p	200	23.5	—	149 pb ⁻¹	783 pb ⁻¹
Year-5	Au+Au	200	23.5	14 nb ⁻¹	48 nb ⁻¹	92 nb ⁻¹

- Consistent with DOE CD-0 “mission need” document
- Incorporates BNL C-AD guidance on luminosity evolution
- Incorporates commissioning time in first year

Minimum bias Au+Au at 15 kHz for $|z| < 10$ cm:

Precision Calorimetry for Jets and Photons

Excellent jet resolution in both p+p and A+A

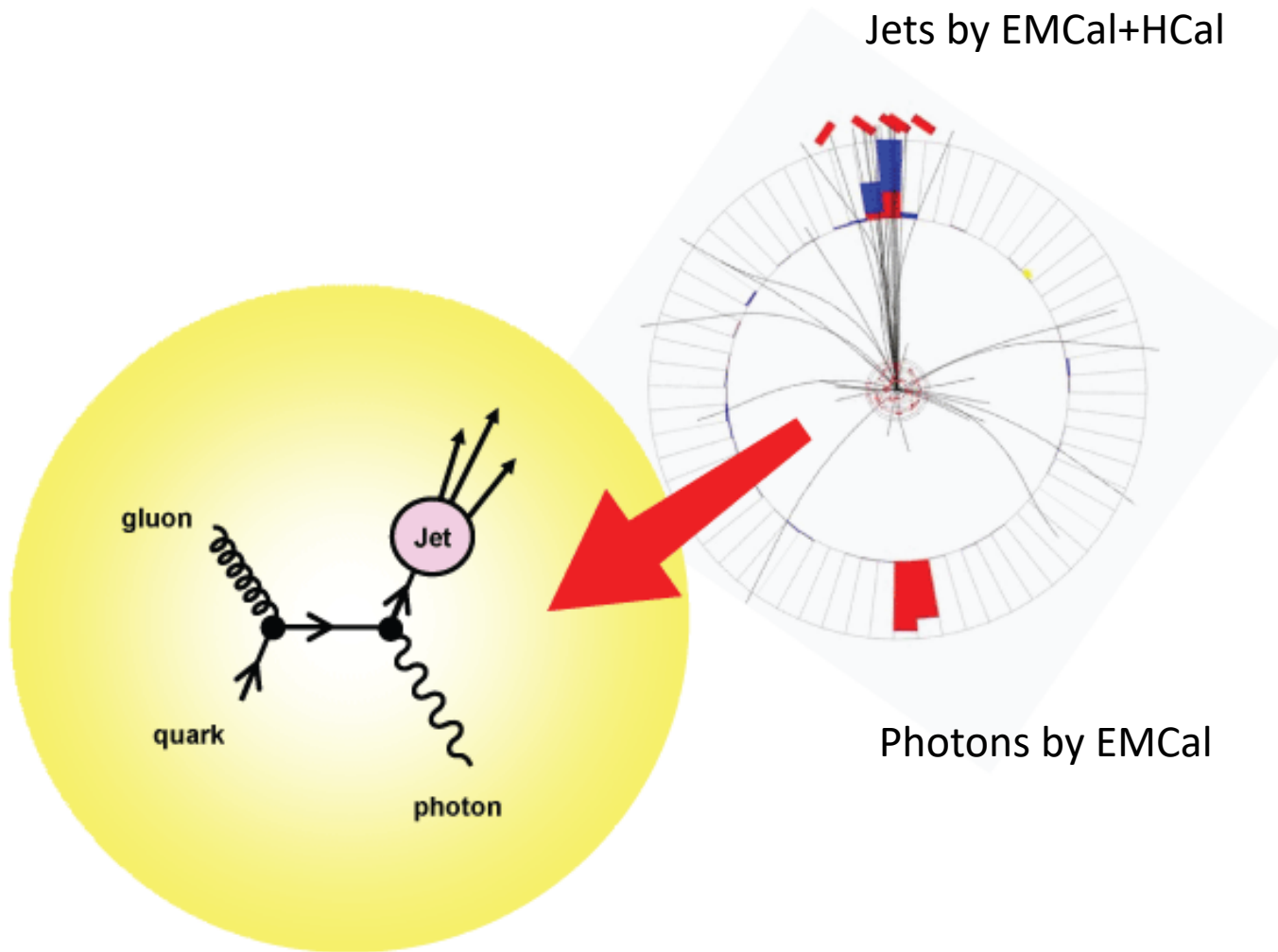
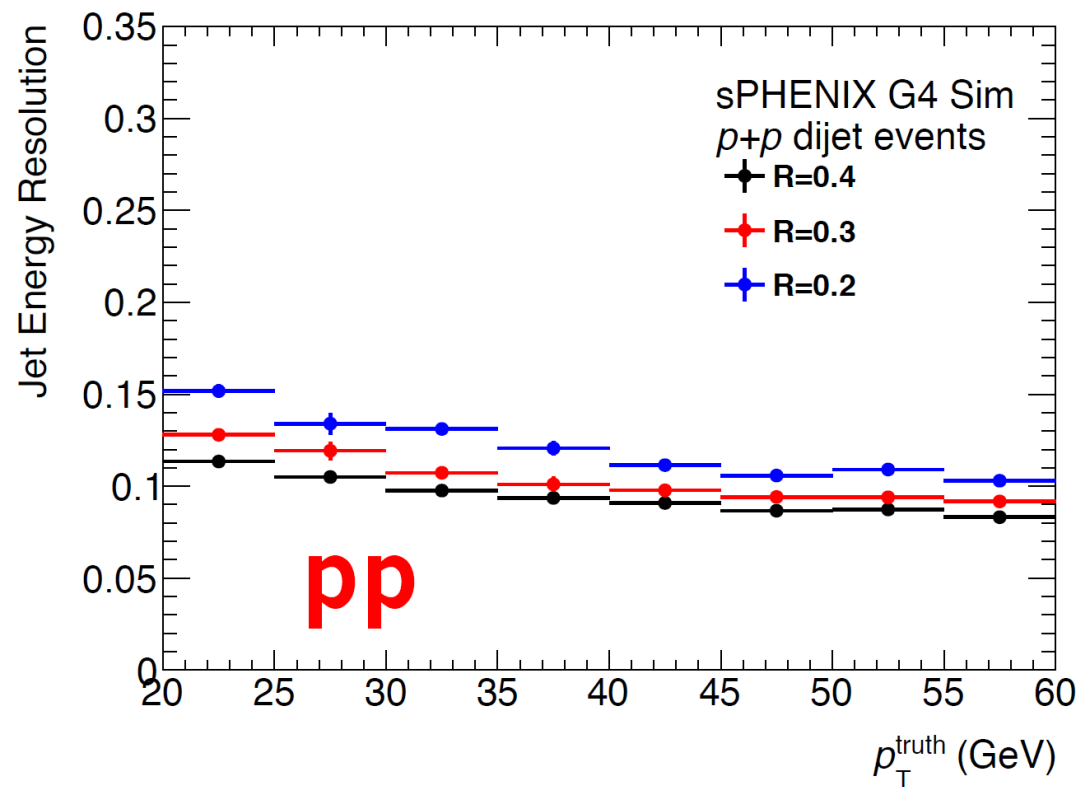

Precision Vertex and Open HF Observables

- Precision vertex tracker + high rate capability
 → Precision open charm and bottom over wide scales

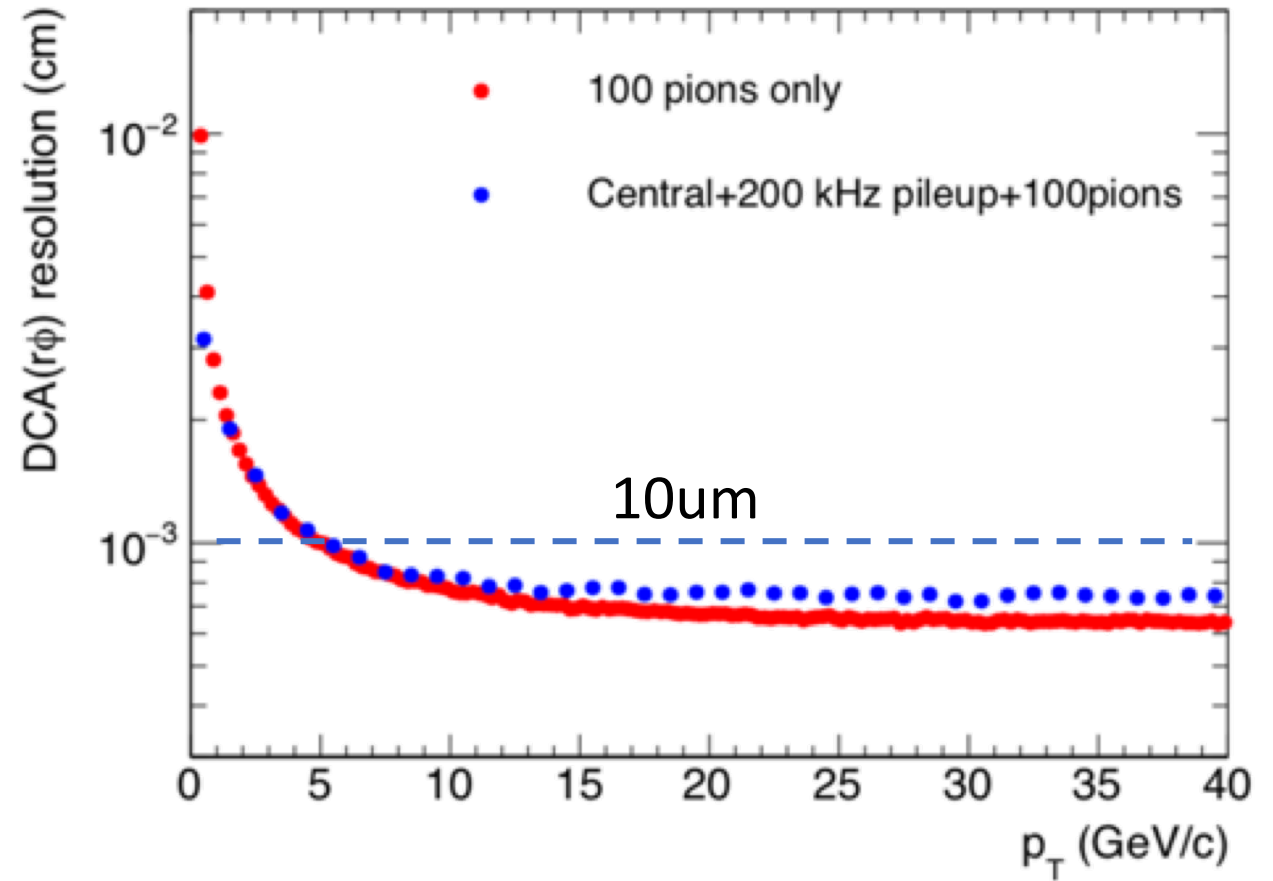
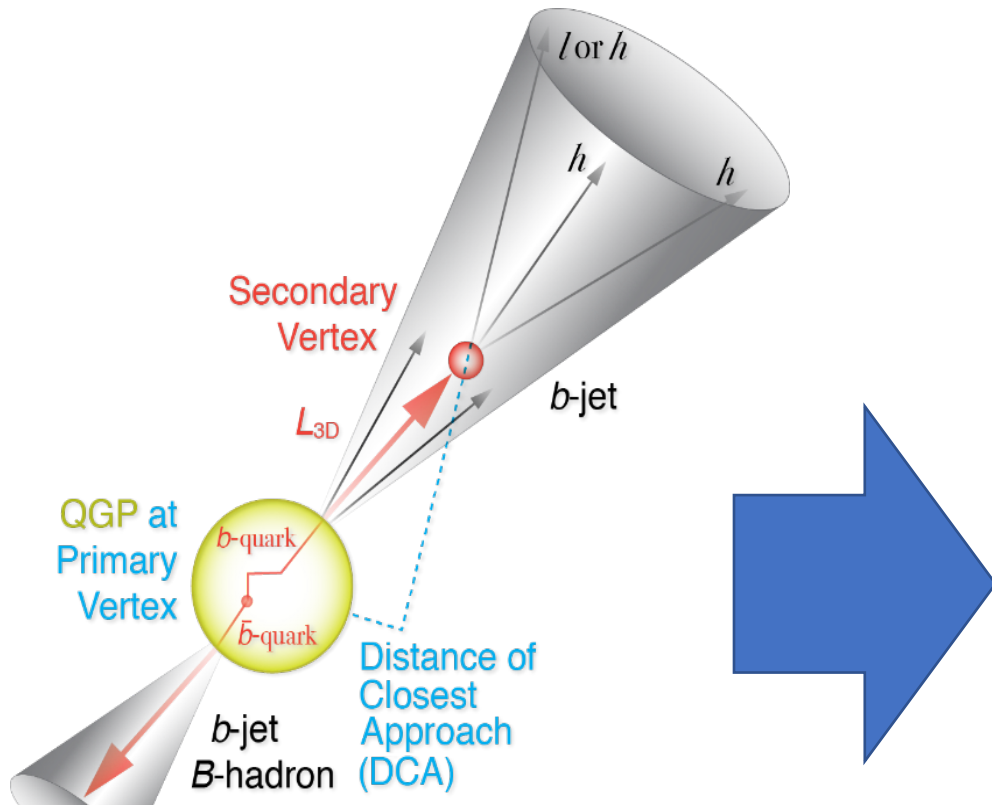

A Broad Physics Program with sPHENIX

- Nuclear matter under extreme condition, "QGP"
- Nucleon and nuclear structures, QCD evolution, "Cold QCD"

"Hot" QGP physics

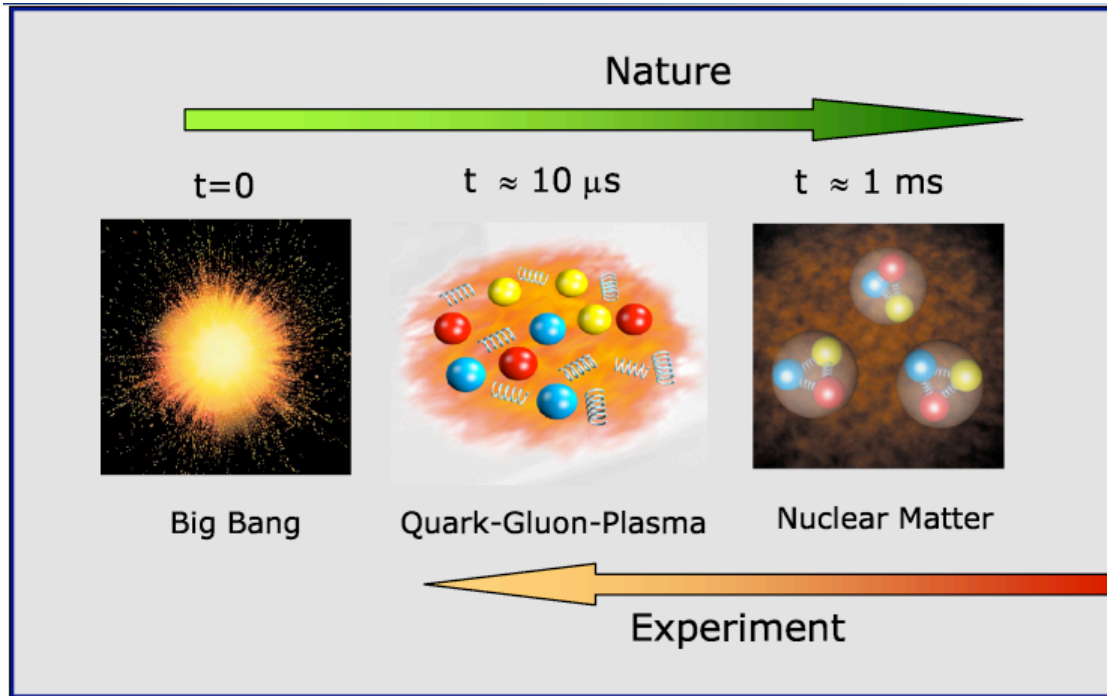

"Cold" QCD physics

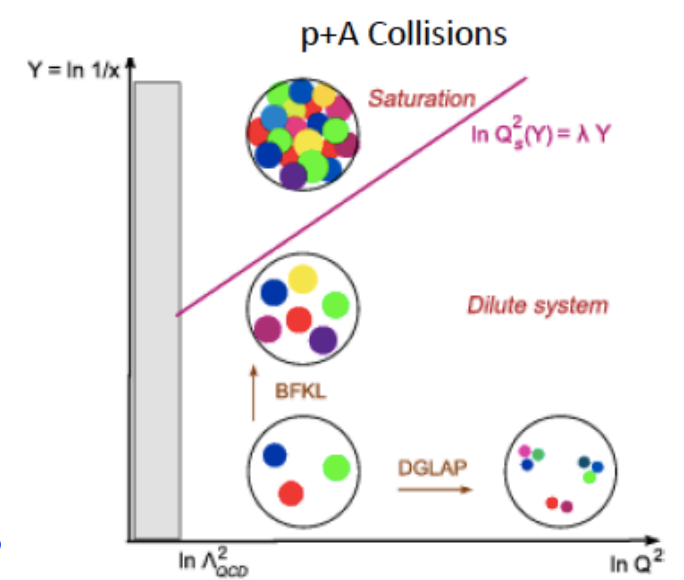
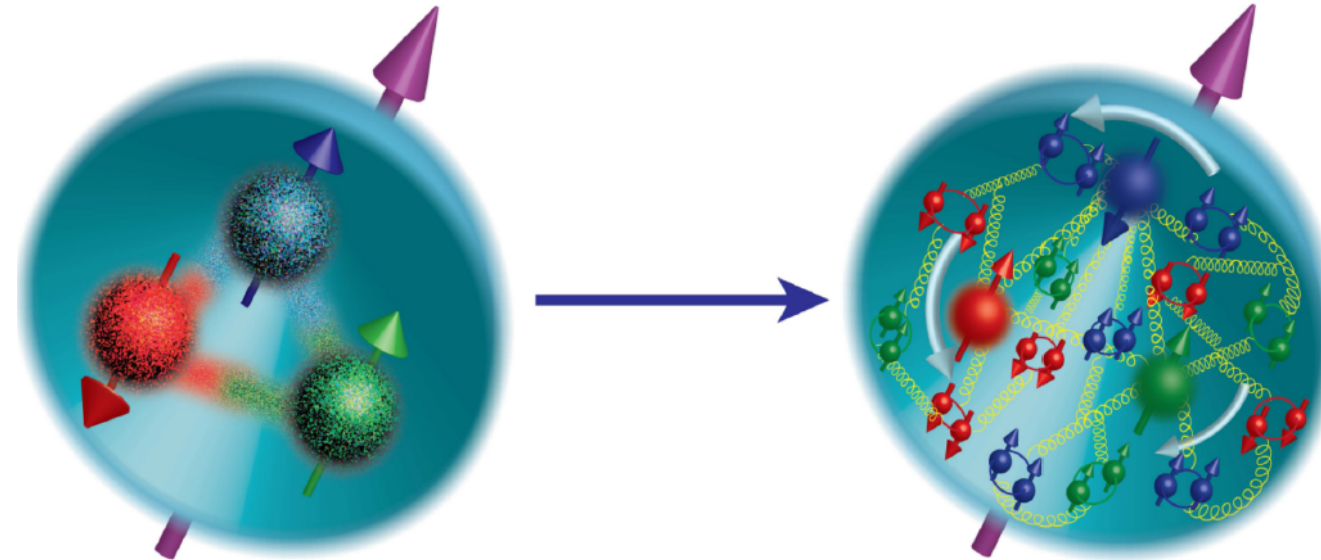

Gluon Polarization

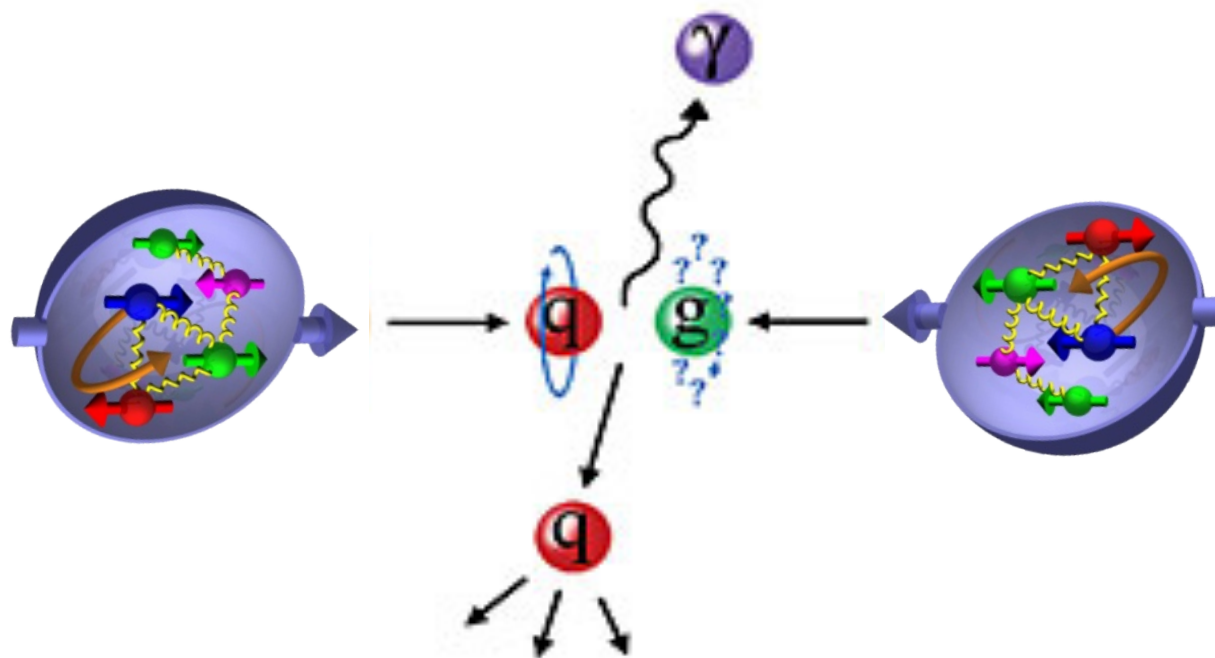

Three Decades of the Proton Spin Puzzle

- Early expectation: large gluon polarization

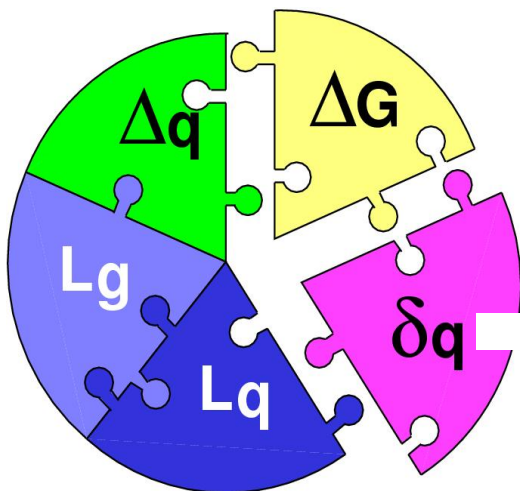

$$\Delta\Sigma' = \Delta\Sigma - \frac{\alpha_s}{2\pi} \cdot \Delta G$$

$$\frac{\alpha_s}{2\pi} \cdot \Delta G = 0.3 \pm 0.1$$

Axial anomaly
Cheng & Li, PRL (1989)

EMC, 1980s

$$\frac{1}{2} = \frac{1}{2}\Delta q + L_q^z + \Delta G + L_g^z$$

$$\Delta q \sim 30\% \quad (SIDIS/DIS)$$

$$\Delta G \sim 40\% \quad (RHIC)$$

$$L \sim ? \quad (RHIC, FNAL?)$$

	Quark Spin	Gluon Spin
SLAC -> 2000	(E80 – E155)	
CERN ongoing	(EMC), (SMC), COMPASS	
DESY ->2007	(HERMES)	
JLab ongoing	Hall A,B,C	
RHIC ongoing	(BRAHMS), (PHENIX), STAR	



SIDIS/DIS



Polarized p+p/hadrons

Gluon Polarization and π^0 (or jet) A_{LL}

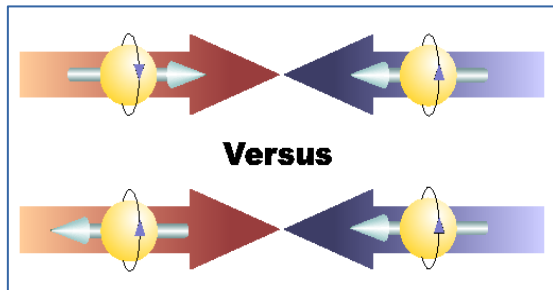

$$A_{LL} = (N^{++} - N^{+-}) / (N^{++} + N^{+-})$$

- Parton distribution functions
- Partonic hard scattering rates
- Fragmentation functions

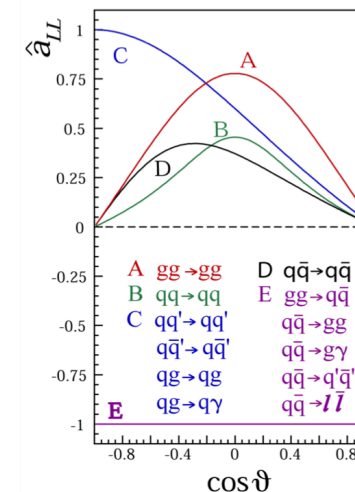

$$\Delta\sigma(pp \rightarrow \pi^0 X) \approx \underbrace{\Delta q(x_1)}_{\text{DIS}} \otimes \underbrace{\Delta g(x_2)}_{?} \otimes \underbrace{\Delta \hat{\sigma}^{qg \rightarrow qg}(\hat{s})}_{\text{pQCD}} \otimes \underbrace{D_q^{\pi^0}(z)}_{\text{e+e-}} \dots$$

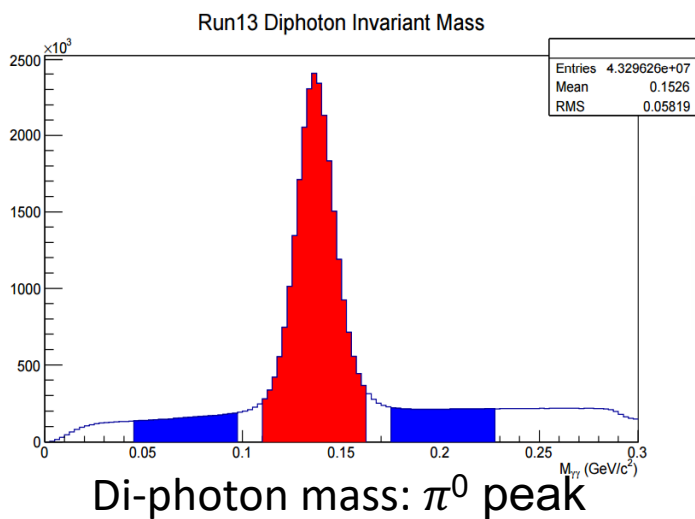

$$A_{LL}^{\pi^0} = \frac{A_{LL}^{\pi^0+BG} - w_{BG} A_{LL}^{BG}}{1 - w_{BG}}$$

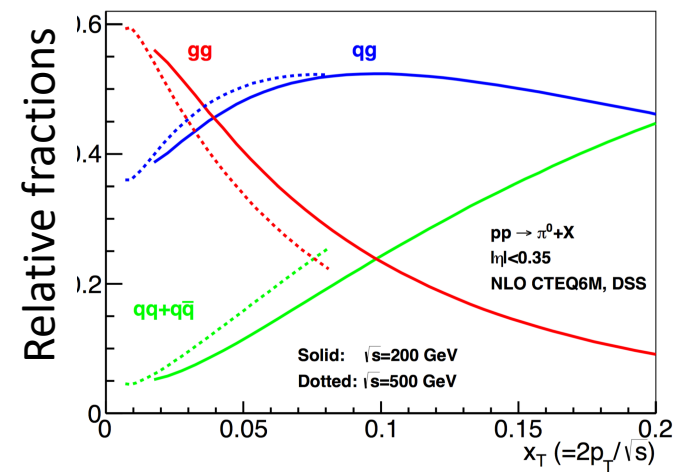

First Hint of Non-zero Gluon Polarization from RHIC

- PHENIX and STAR A_{LL} data

STAR: PRL 115, 092002 (2015)

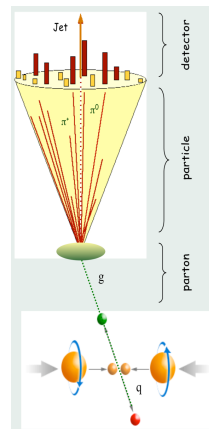
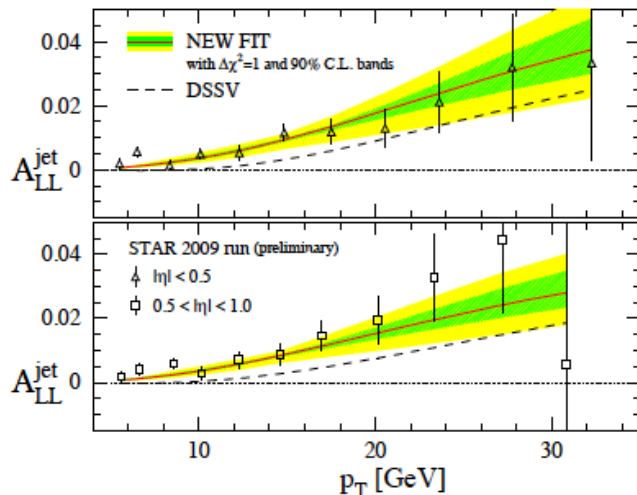

$$\int_{0.05}^1 \Delta g(x, Q^2) dx = 0.2^{+0.06}_{-0.07}$$

@ $Q^2 = 10 \text{ GeV}^2$

PRL 113, 012001 (2014), DSSV

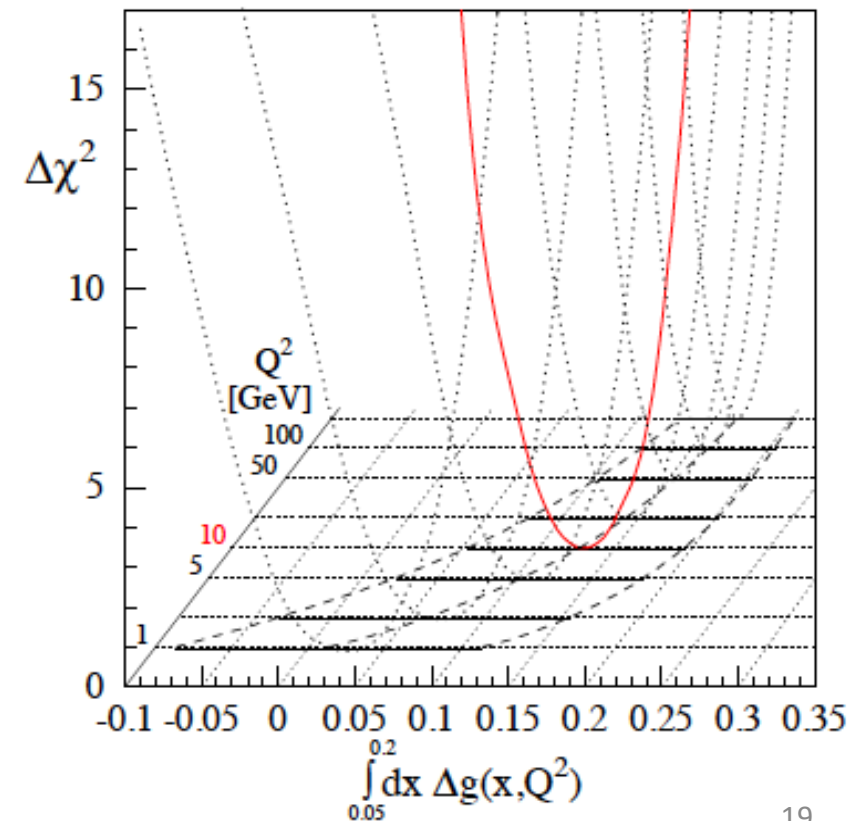

PHENIX: PRD 90, 012007 (2014)

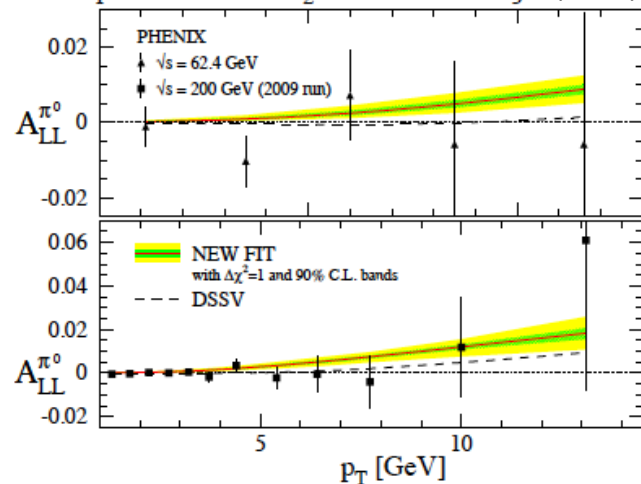

Run 2009
p+p@200GeV

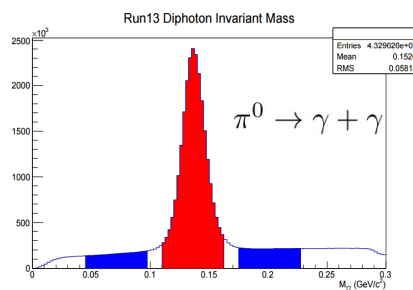

Cold-QCD Physics with sPHENIX

RHIC Multi-Year Plan: sPHENIX 2023-2027+ (Cold QCD plan under development now)



- Jets, hadrons, direct photons and more
- Study gluon polarization

Ref: RHIC 2015 pp200
Recorded lumi $\sim 50\text{pb}^{-1}$

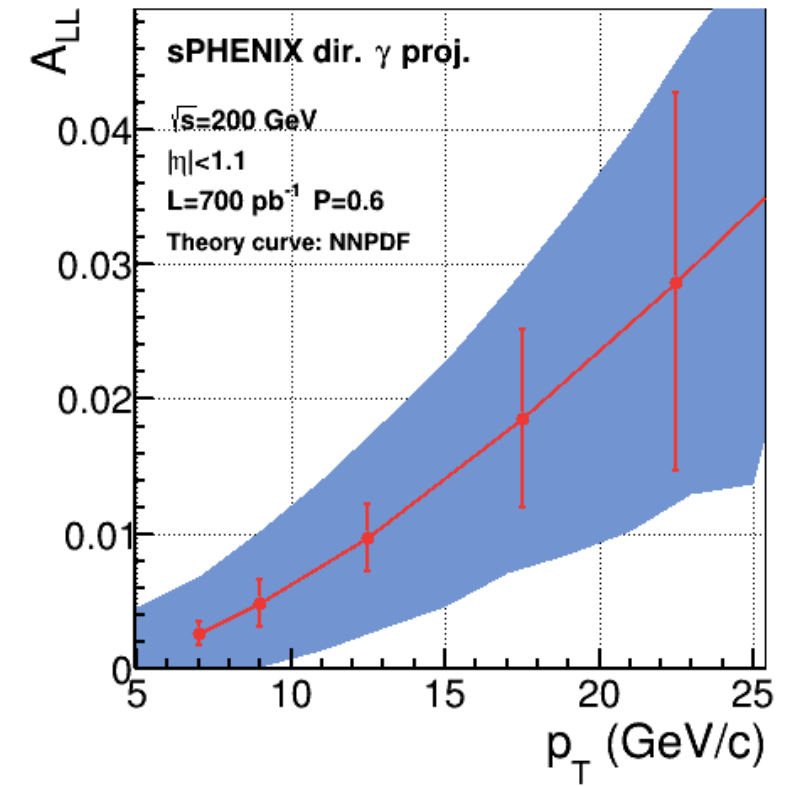
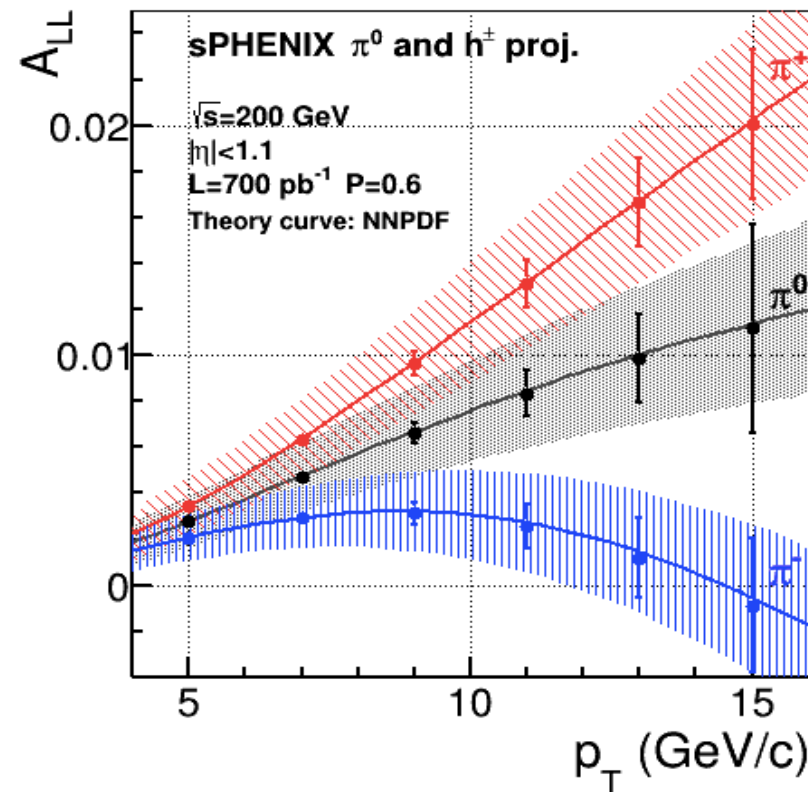
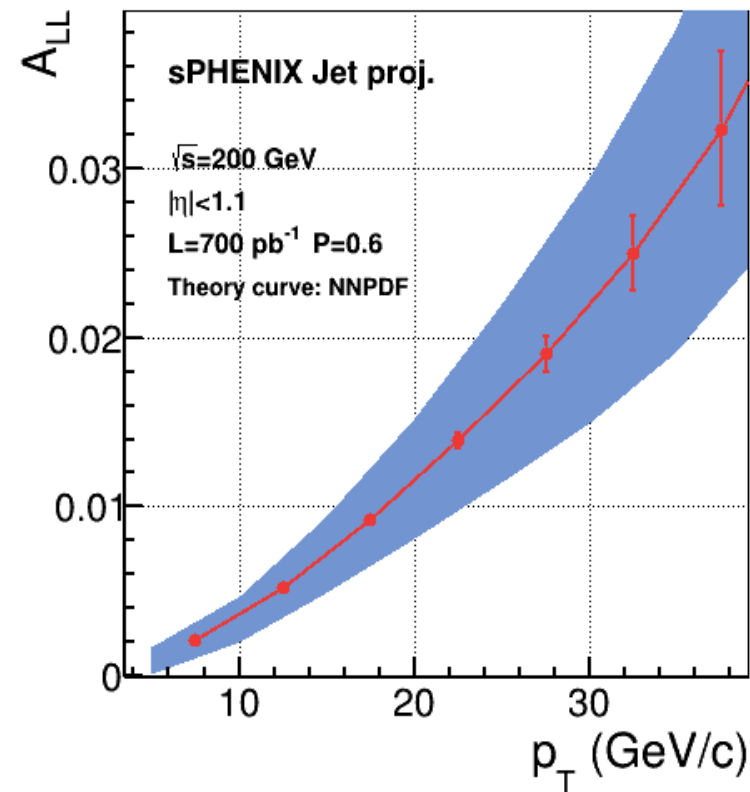

Physics with Transversely Polarized p+p Collisions at RHIC

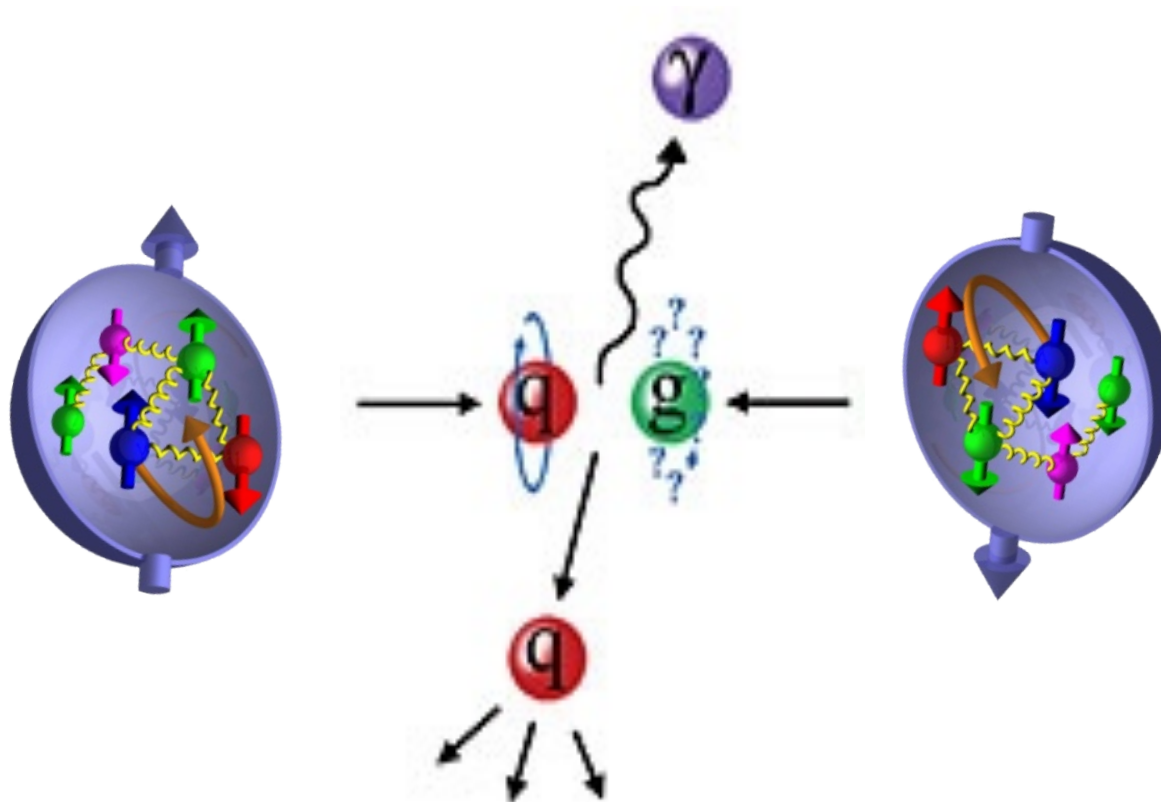
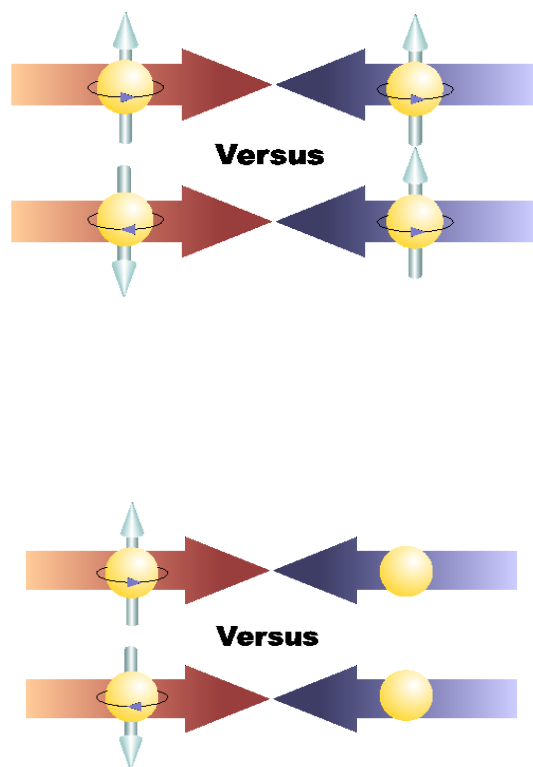

“TMD” phenomena: The Challenge of “Too Large”

Large Transverse Single Spin Asymmetry (TSSA) in forward hadron production persists up to top RHIC energy

$$A_N \sim O(10\%)$$

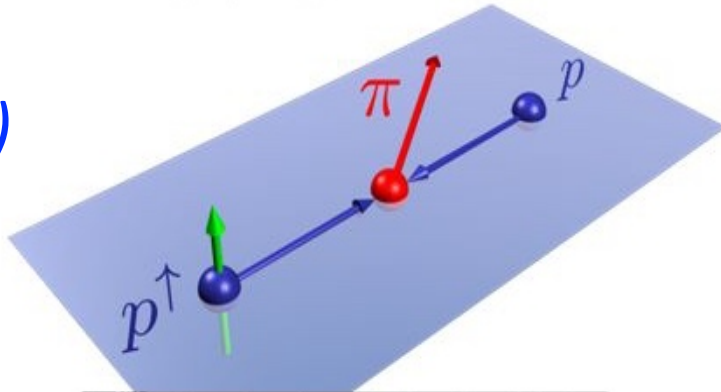

Kane, Pumplin, Repko (1978)

$$A_N = \frac{\sigma^\uparrow - \sigma^\downarrow}{\sigma^\uparrow + \sigma^\downarrow}$$

Fermilab
E704 (1991)

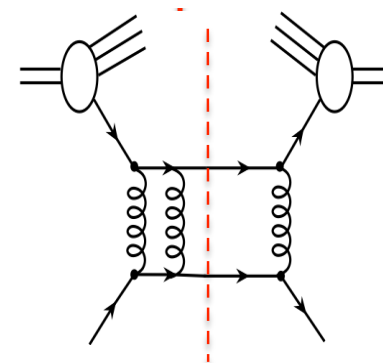
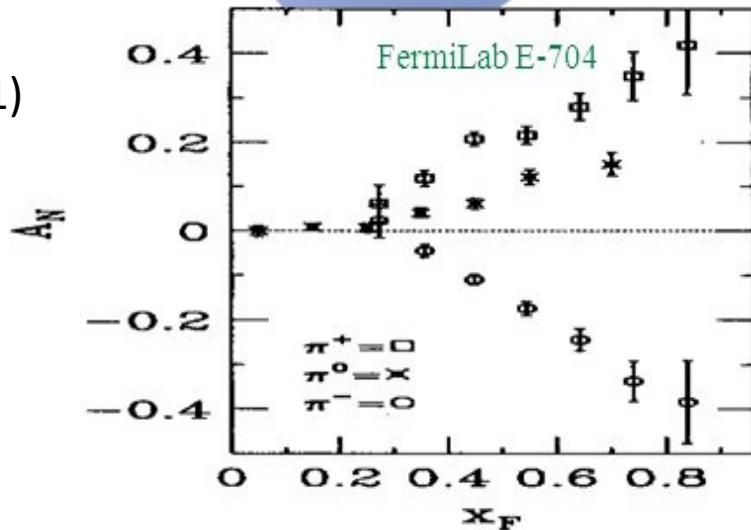

$$\propto \alpha_s \frac{m_q}{p_T}$$

$$A_N^{(pred.)} \sim 0$$

Probe the Underlying Physics via Hard Scatterings

TMD, Collinear Twist-3 Factorizations

(i) Sivers mechanism:

correlation proton spin & parton k_T

SIDIS:

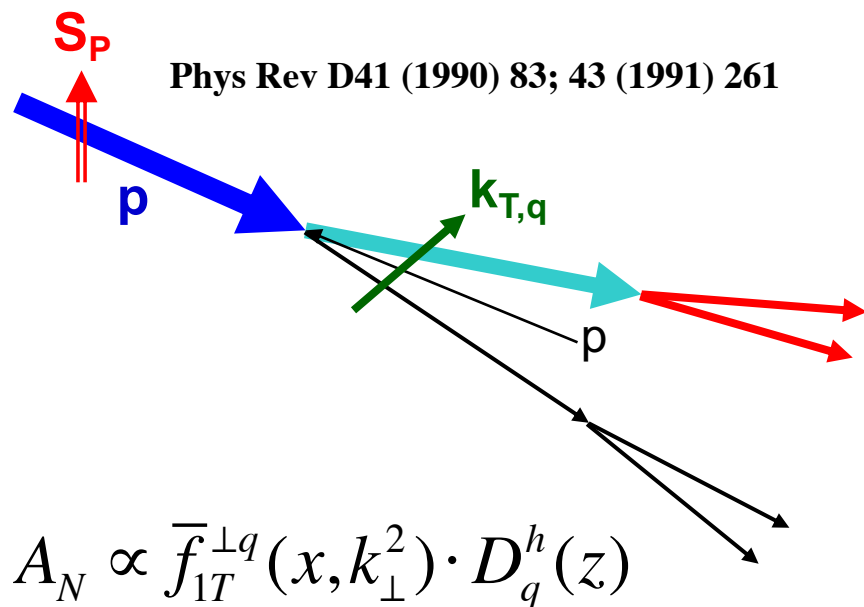

(ii) Collins mechanism:

Transversity \times spin-dep fragmentation

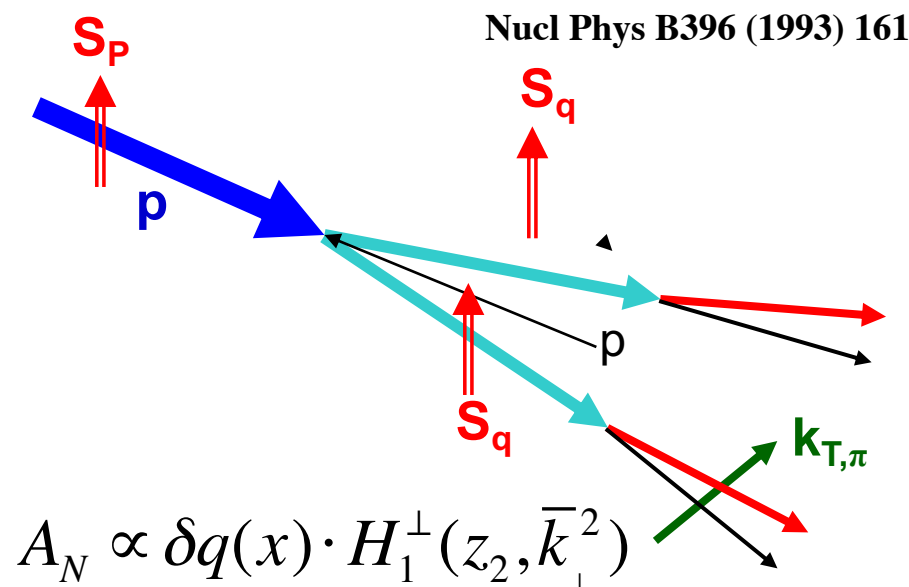

pp:

Collinear Twist-3 (RHIC): quark-gluon/gluon-gluon correlations

Collins-Like Asymmetry Observed in Jet in p+p Collisions

Projections for sPHENIX in progress;
 -> Inclusive single hadron TSSA in p+p seems mostly from Twist-3 Collins function

None-zero “Collins-like” TSSA at central rapidity in jet!

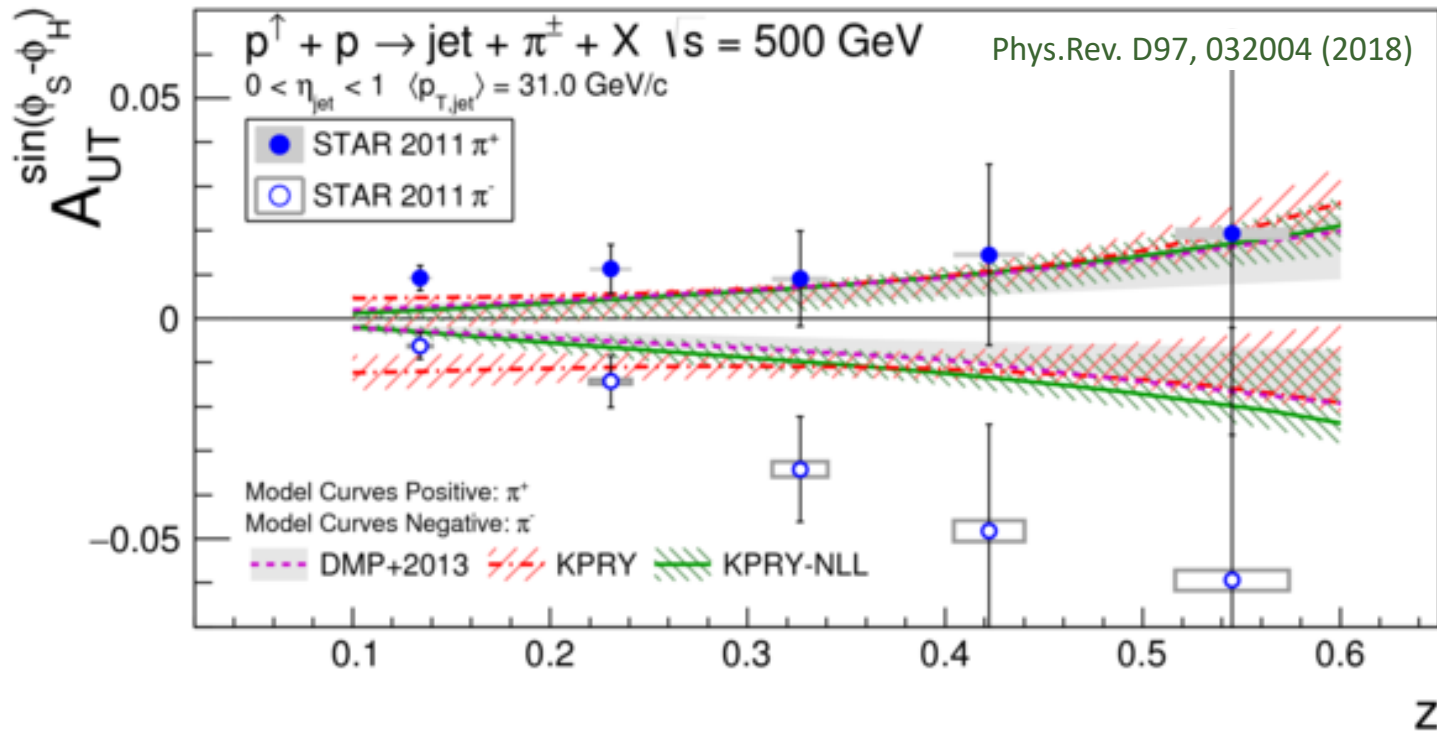

Inclusive hadron $A_N = 0$ at central rapidity

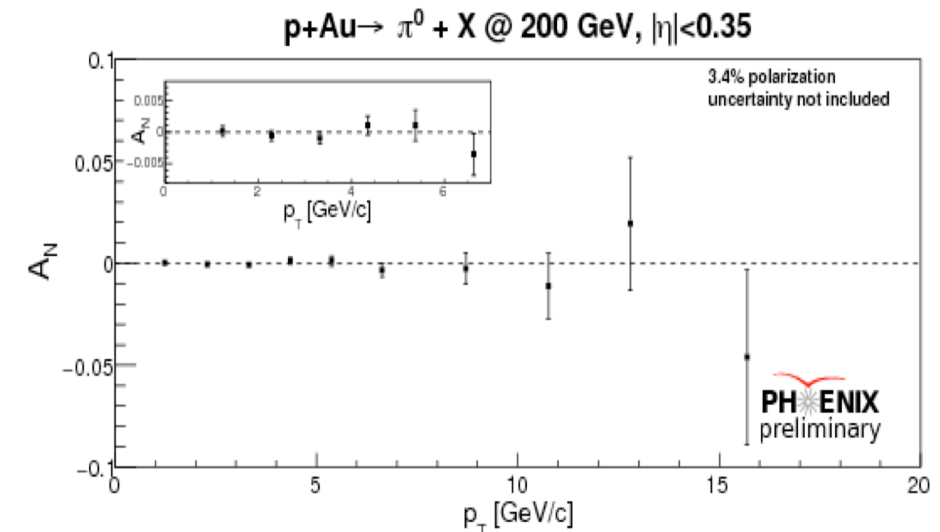
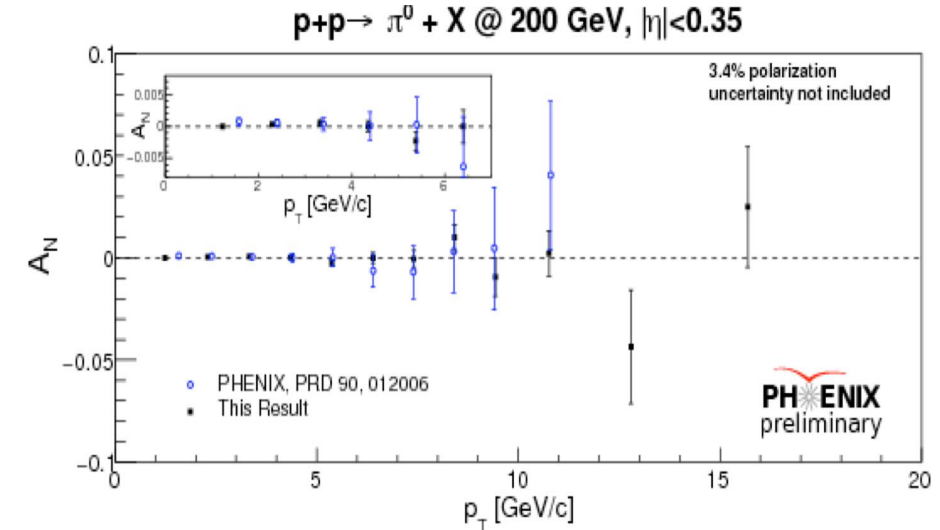

Probe Gluon TMD with D^0

Charm is unique probe of gluon TMD

$D^0_{AN} \rightarrow$ Tri-gluon correlation

PHENIX, DOI:10.1103/PhysRevD.95.112001

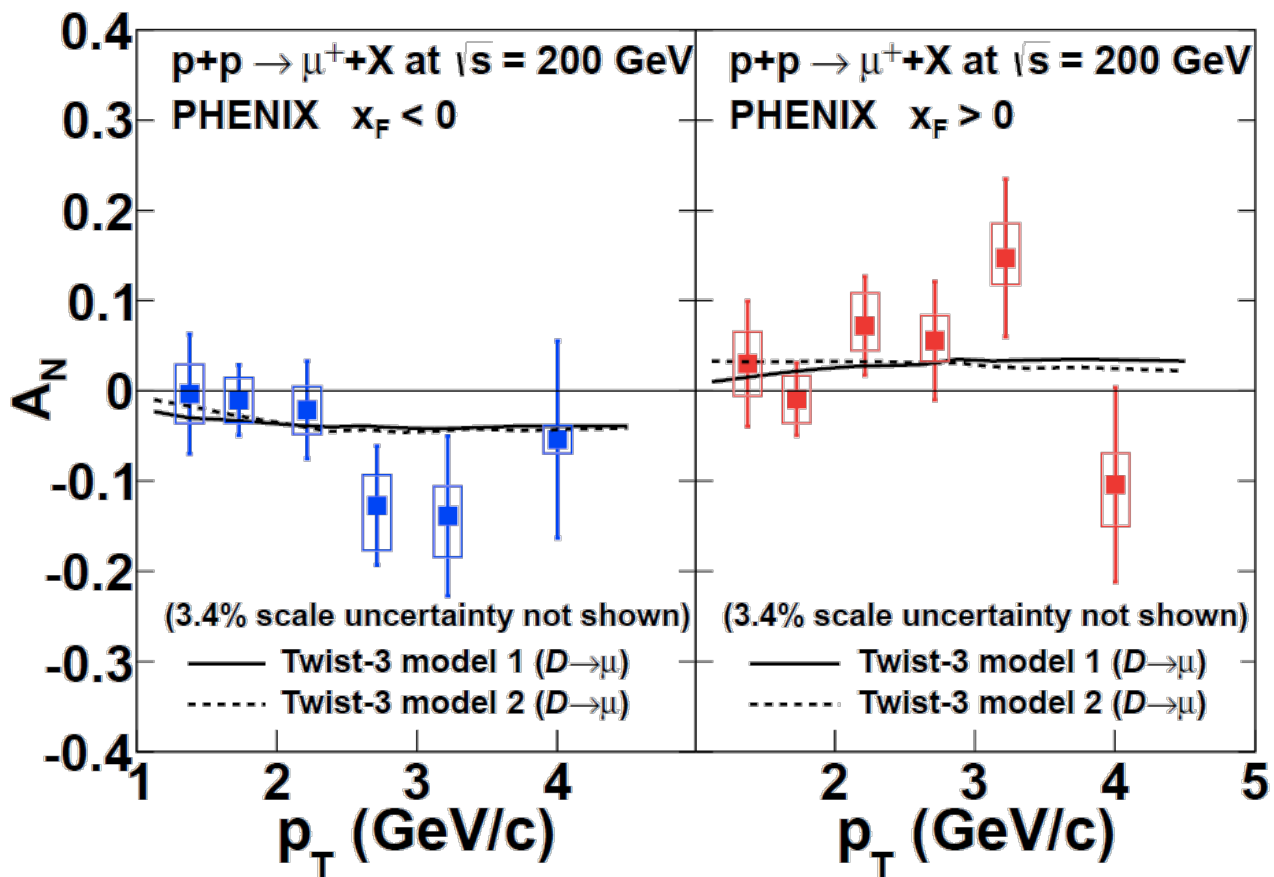

sPHENIX projection

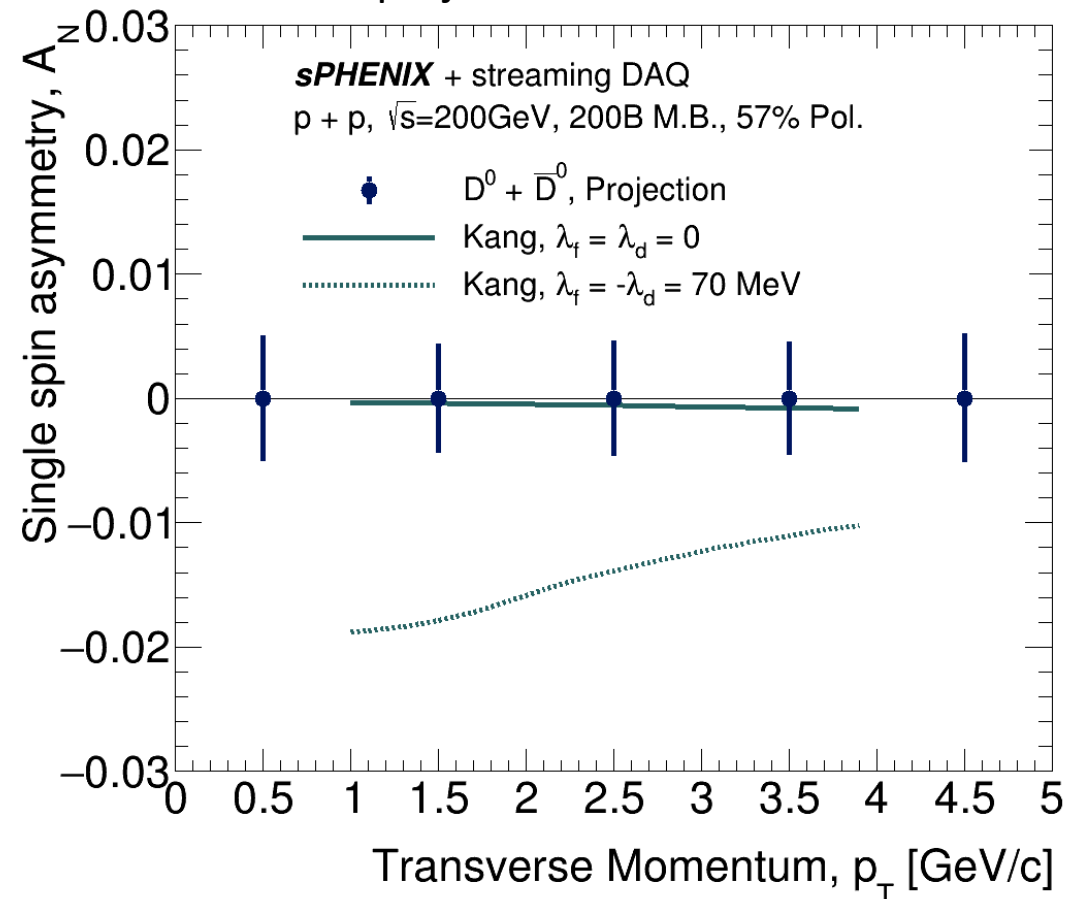

Forward Upgrade Proposal

Forward upgrade will bring in new physics capability – TMD, small-x physics etc.

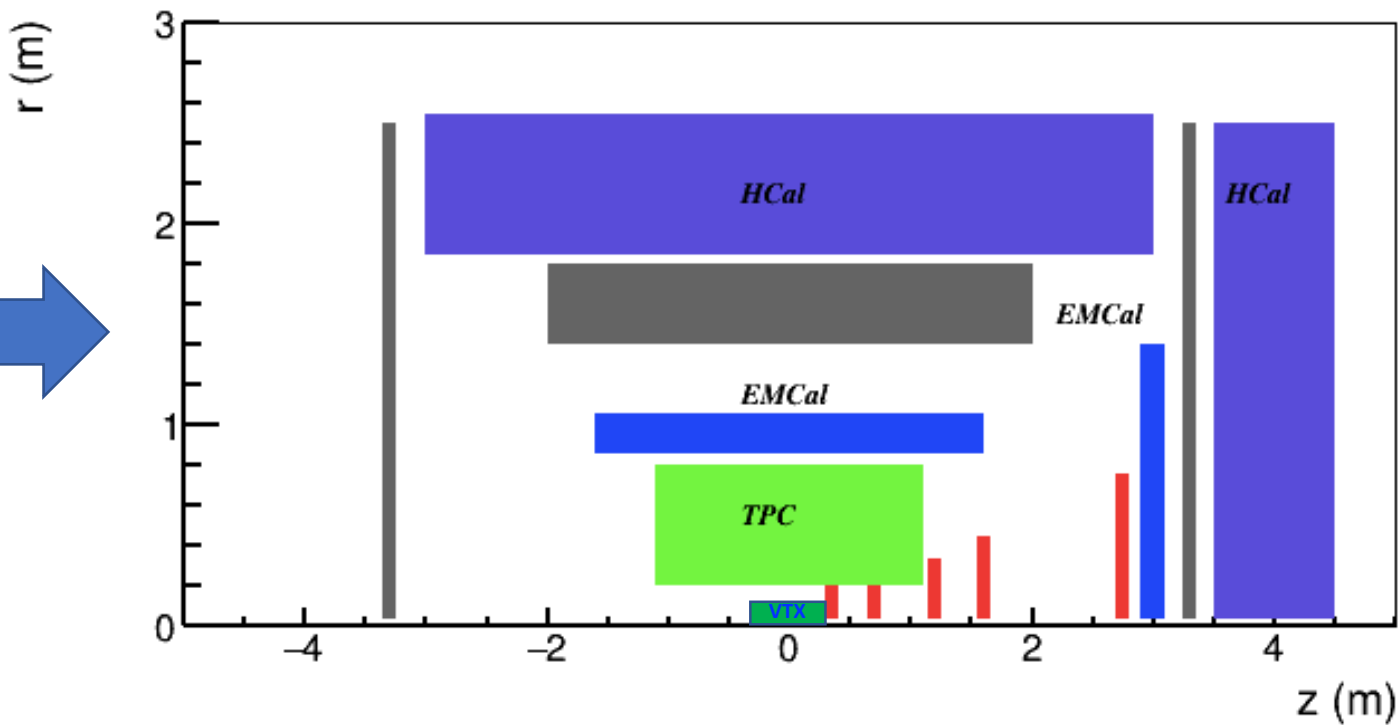
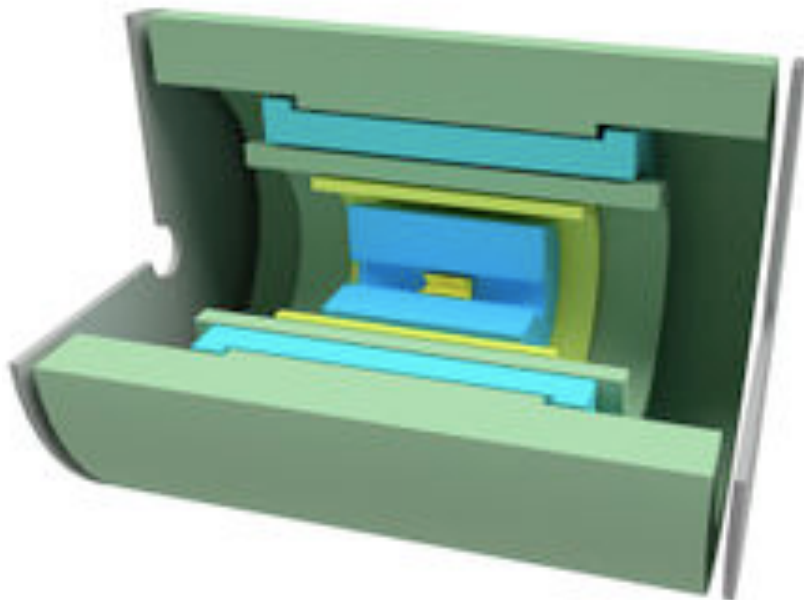

sPHENIX Barrel Detectors:

- MVTX, INTT, TPC
- EMCAL, HCal

sPHENIX Forward Upgrade

- EMCAL, Hcal, Tracking

Access Sivers and Collins with Jet and Hadron Azimuthal Distributions in Transversely Polarized p+p Collisions

Feng Yuan, PRL 100, 032003 (2008)
 Umberto D'Alesio et al PRD 83 034021 (2011)

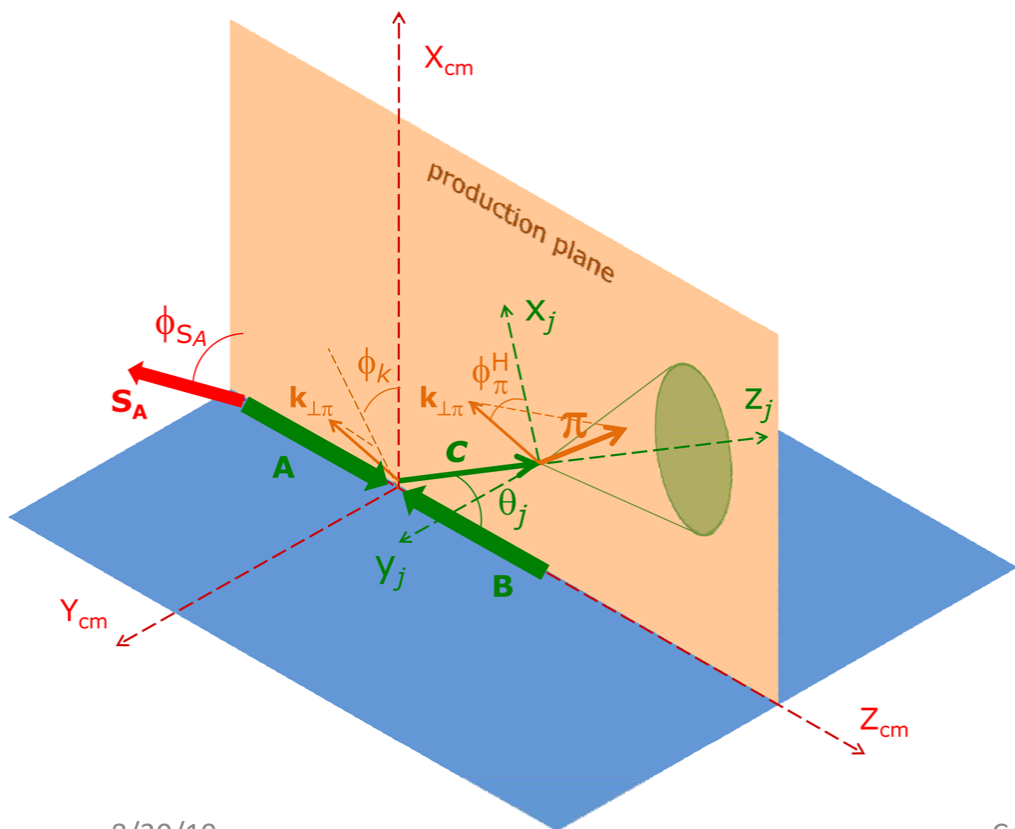

$$\frac{E_j d\sigma^{A(S_A)B \rightarrow \text{jet} + \pi + X}}{d^3 p_j dz d^2 k_{\perp \pi}} = \sum_{a,b,c,d,\{\lambda\}} \int \frac{dx_a dx_b}{16\pi^2 x_a x_b s} d^2 k_{\perp a}$$

$$\times d^2 k_{\perp b} \rho_{\lambda_a \lambda'_a}^{a/A, S_A} \hat{f}_{a/A, S_A}(x_a, \mathbf{k}_{\perp a}) \rho_{\lambda_b \lambda'_b}^{b/B} \hat{f}_{b/B}(x_b, \mathbf{k}_{\perp b})$$

$$\times \hat{M}_{\lambda_c, \lambda_d; \lambda_a, \lambda_b} \hat{M}_{\lambda'_c, \lambda'_d; \lambda'_a, \lambda'_b}^* \delta(\hat{s} + \hat{t} + \hat{u}) \hat{D}_{\lambda_c, \lambda'_c}^{\pi}(z, \mathbf{k}_{\perp \pi}).$$

$$A_N \sin \phi_{S_A} \rightarrow \text{“Sivers-like” (Jet)}$$

$$A_N \sin(\phi_{S_A} \mp \phi_{\pi}^H) \rightarrow \text{“Collins-like” (hadron)}$$

Precision Charged Tagged Jet TSSA

Naïve direct mapping
from SIDIS Sivers (GPM)
- “u-quark jet” $A_N > 0$

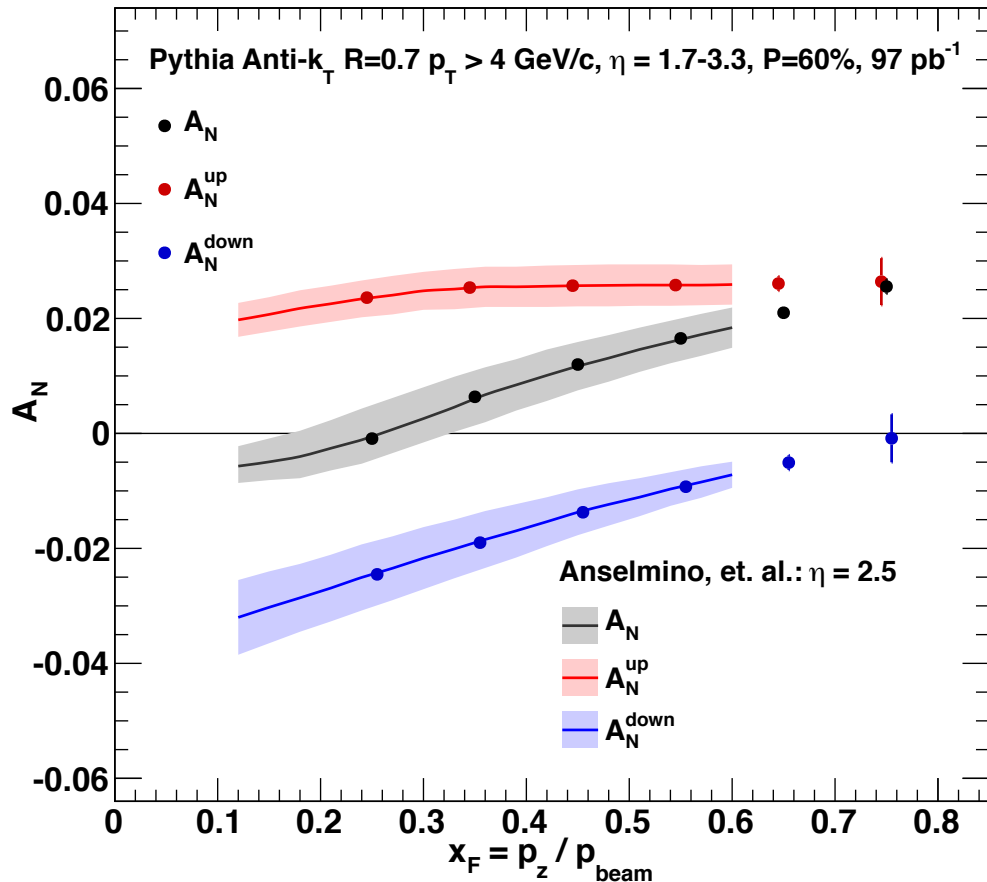

With process-dependence
from SIDIS Sivers (Twist-3)
- “u-quark jet” $A_N < 0$

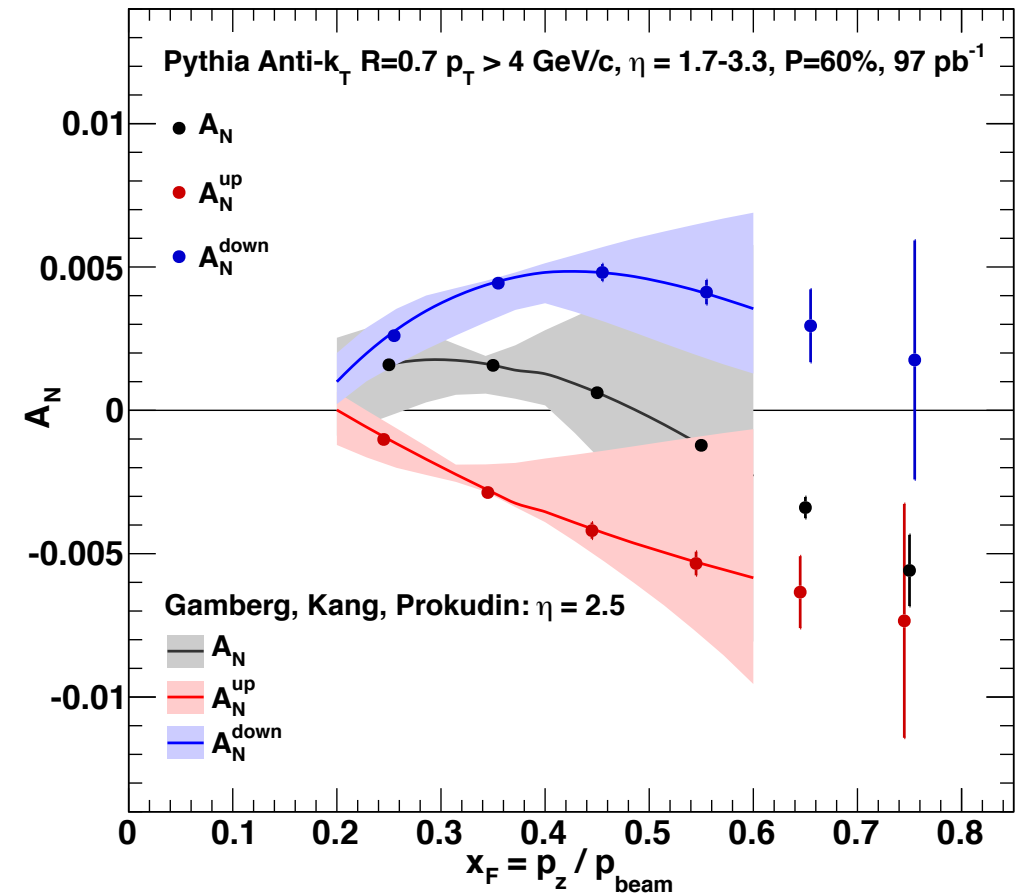

Drell-Yan in the Forward Rapidity: p+A

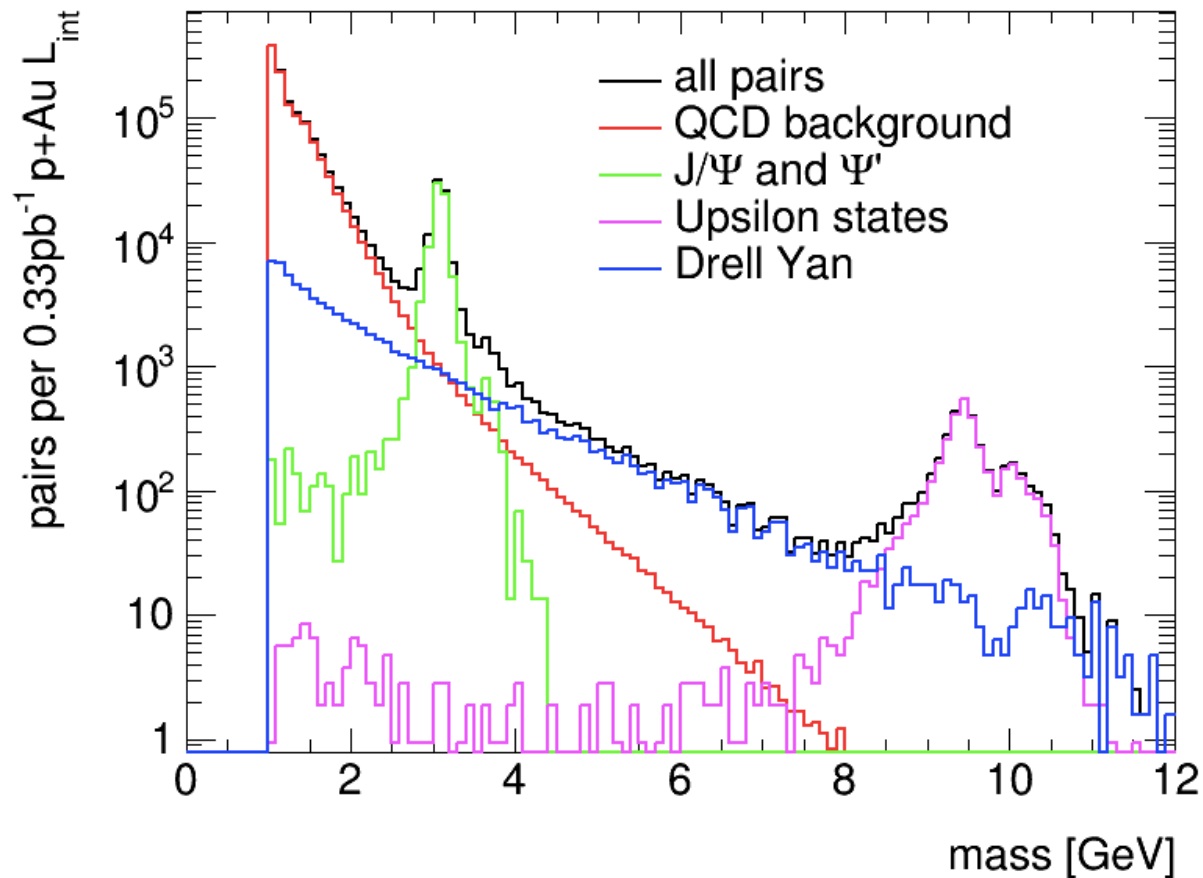
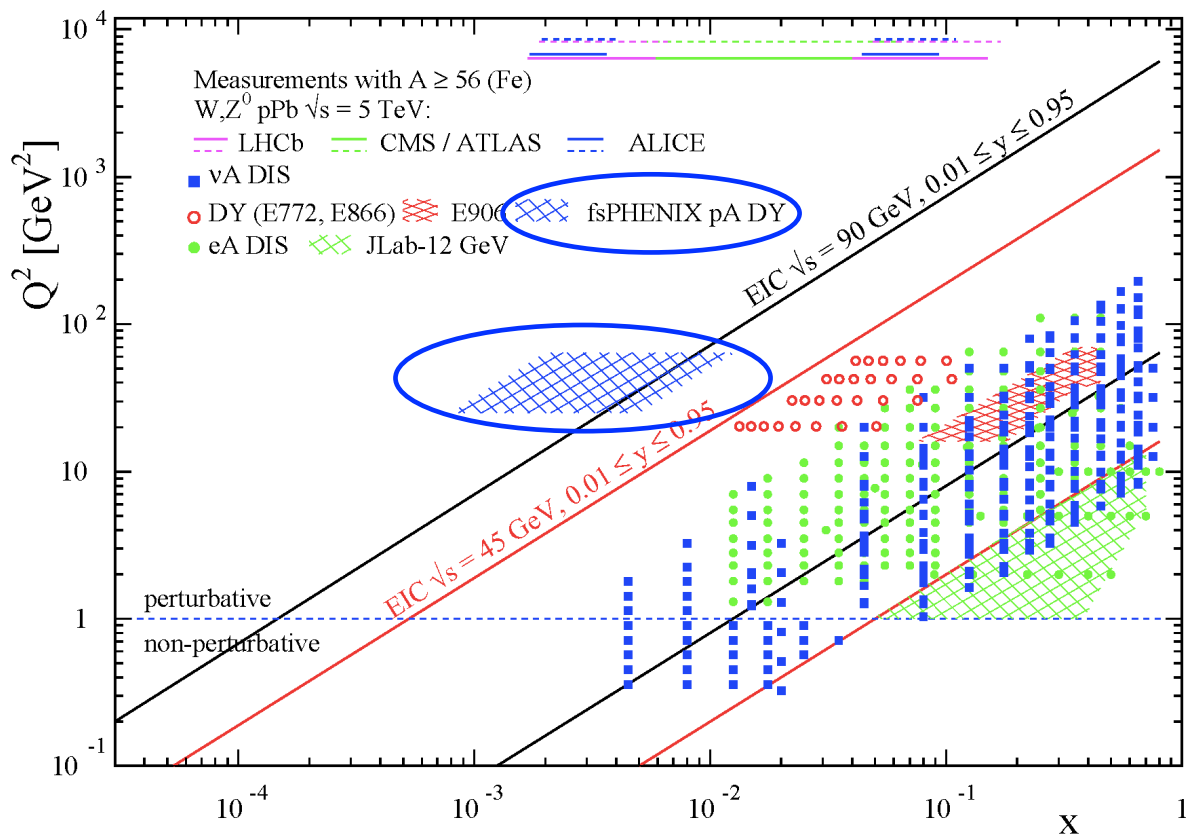

Forward EMCal R&D

- Recycled Modules from AGS/E864

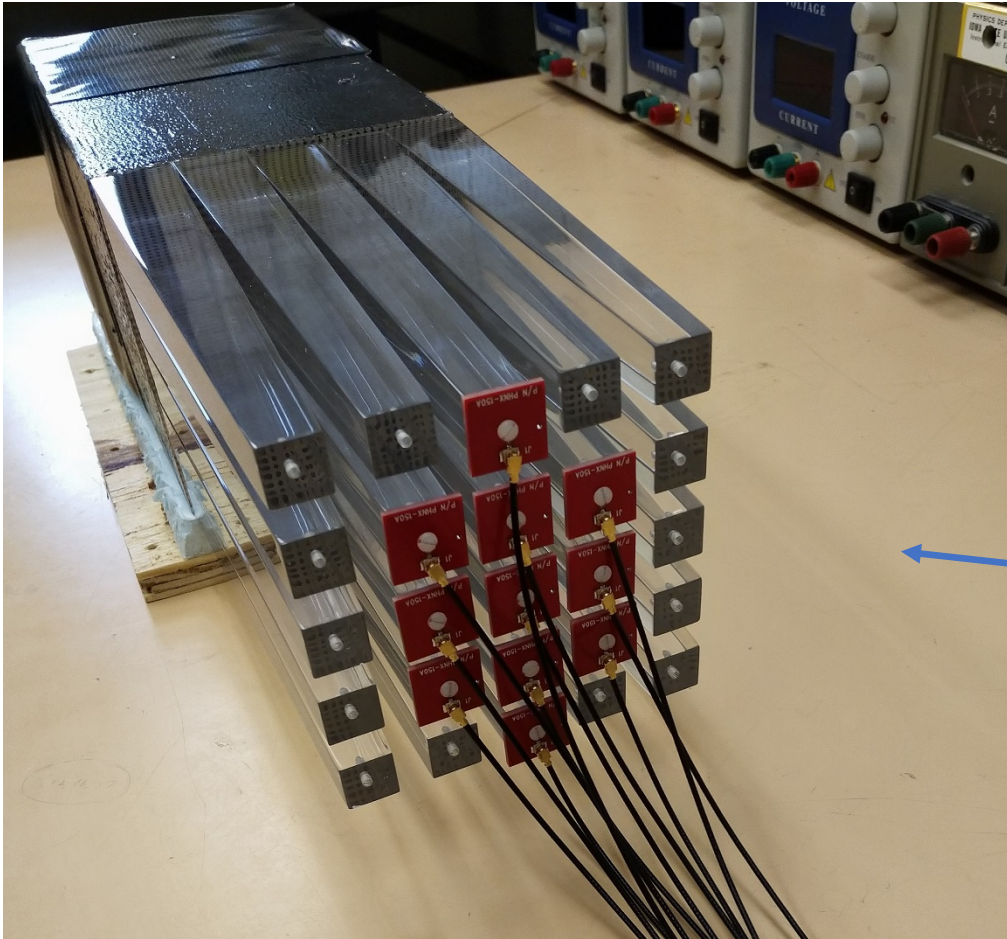

Use the existing E864 HCal modules for high density and high granularity EMCal

- Compensating SPACAL design: $10 \times 10 \times 117 \text{ cm}^3$
- $X_0 = 7.8 \text{ mm}$, $RM = 2 \text{ cm}$
- 5×5 light guide array for $10 \times 10 \text{ cm}^2$ modules $\Rightarrow 2 \times 2 \text{ cm}^2$
- 117 cm long $\Rightarrow 7$ cuts for 16 cm long modules ($20 X_0$)

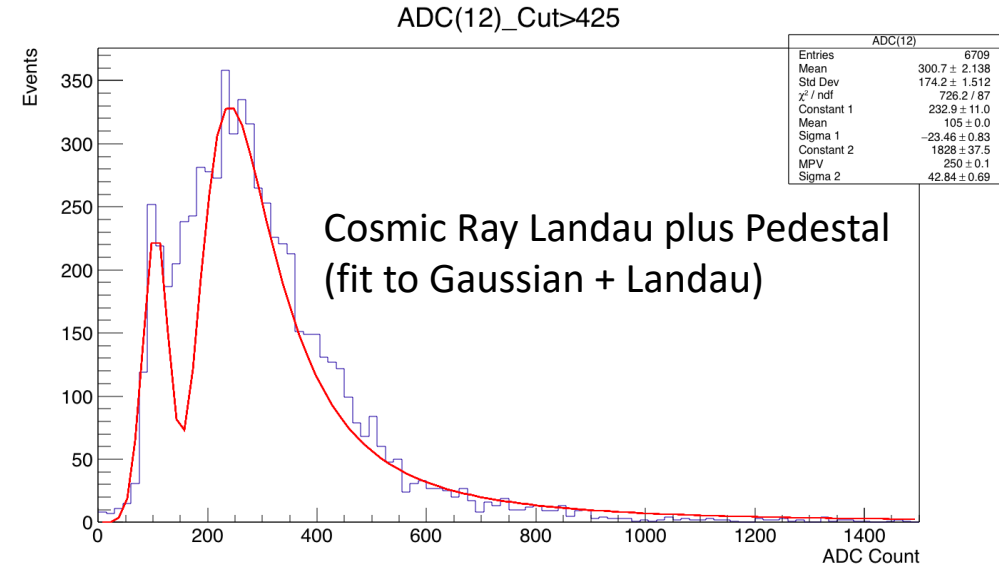

Forward EMCal Simulations and Calibration

Full simulation setup exists in G4:

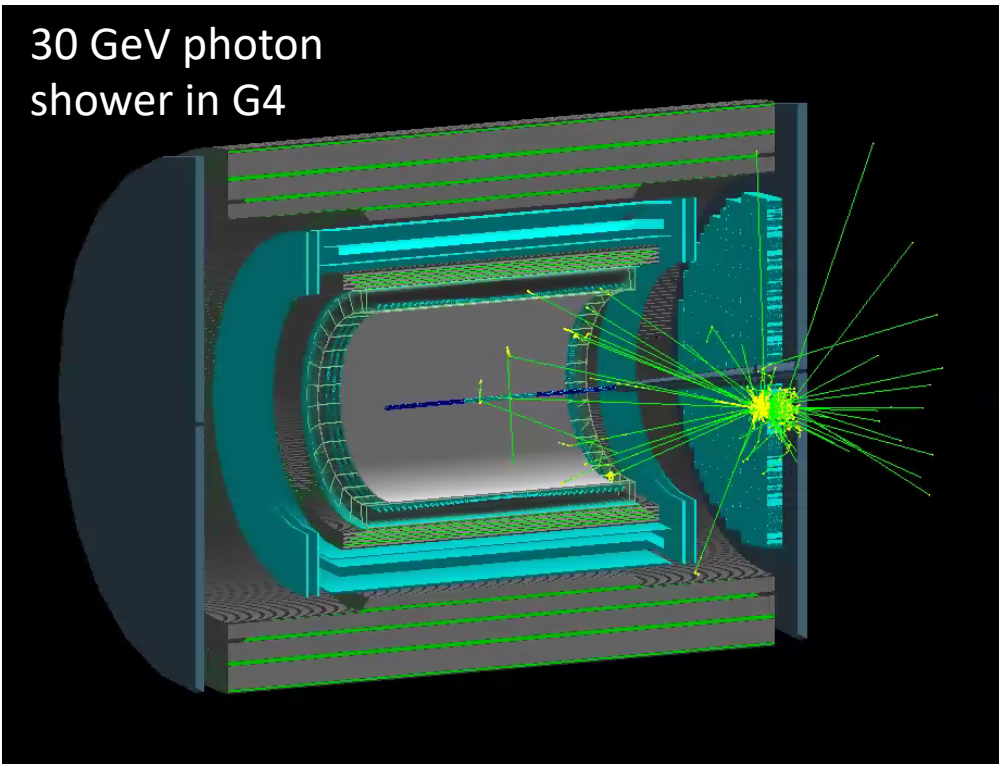

Cosmics energy response determined with vertical muons down into fEMC stack in standard G4 setup (3% sampling):

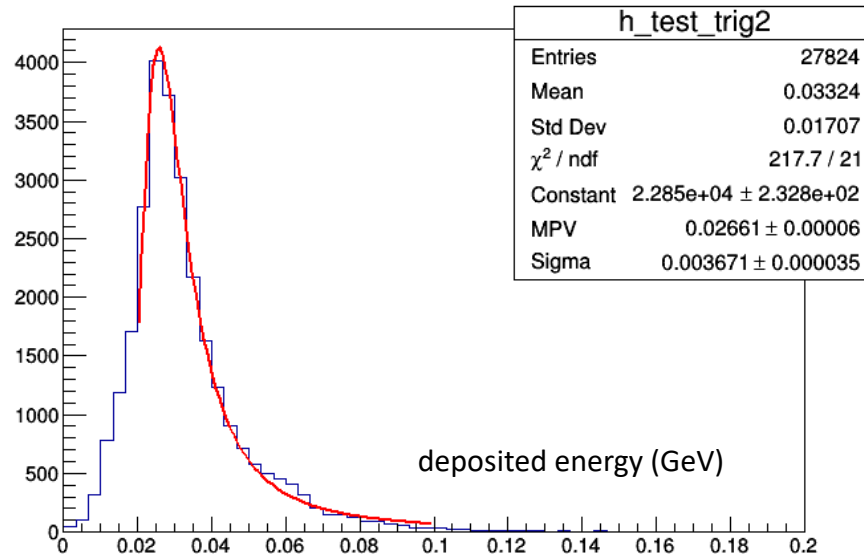

MPV is 26.6 MeV

$\sim 3 \text{ pixels} / 0.0266 \text{ GeV} =$
 $113 \text{ SiPM pixels/GeV}$

NIM A 406 (1998) 227-258:

- $136 \pm 5 \text{ p.e. /GeV}$
(BCF-10, cosmics)
- $217 \pm 68 \text{ p.e. /GeV}$
(BCF-12, laser)

Forward Hadronic Calorimeter R&D

- Essential for forward jet reconstruction, hadron energy measurement, and triggering
- Collaboration with UCLA group for STAR upgrade and EIC detector R&D

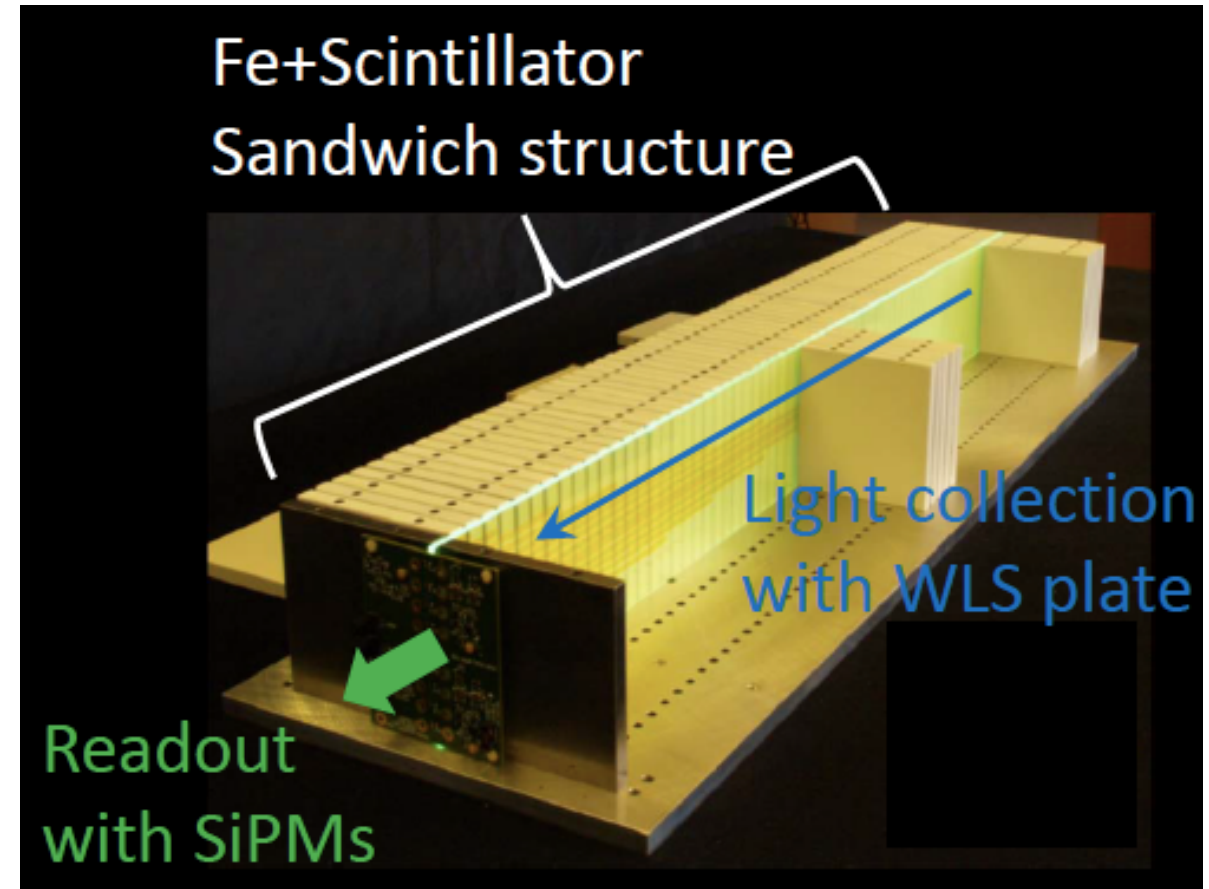

HCal Prototype Test Beam Results

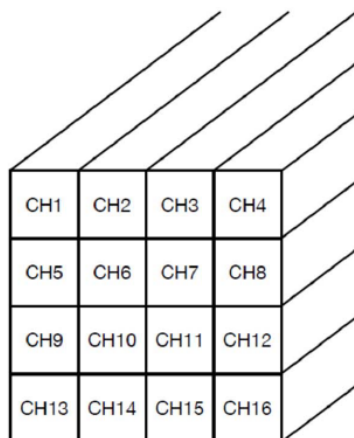
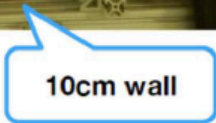
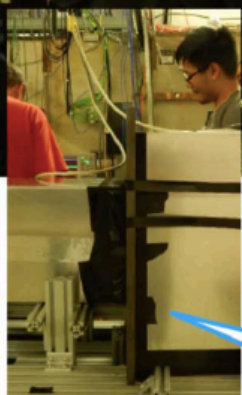

$$\sigma_E/E = 70\%/\sqrt{E} \text{ (GeV)}$$

Calorimeters consist of 4x4 towers.

Beam energy vs Resolution

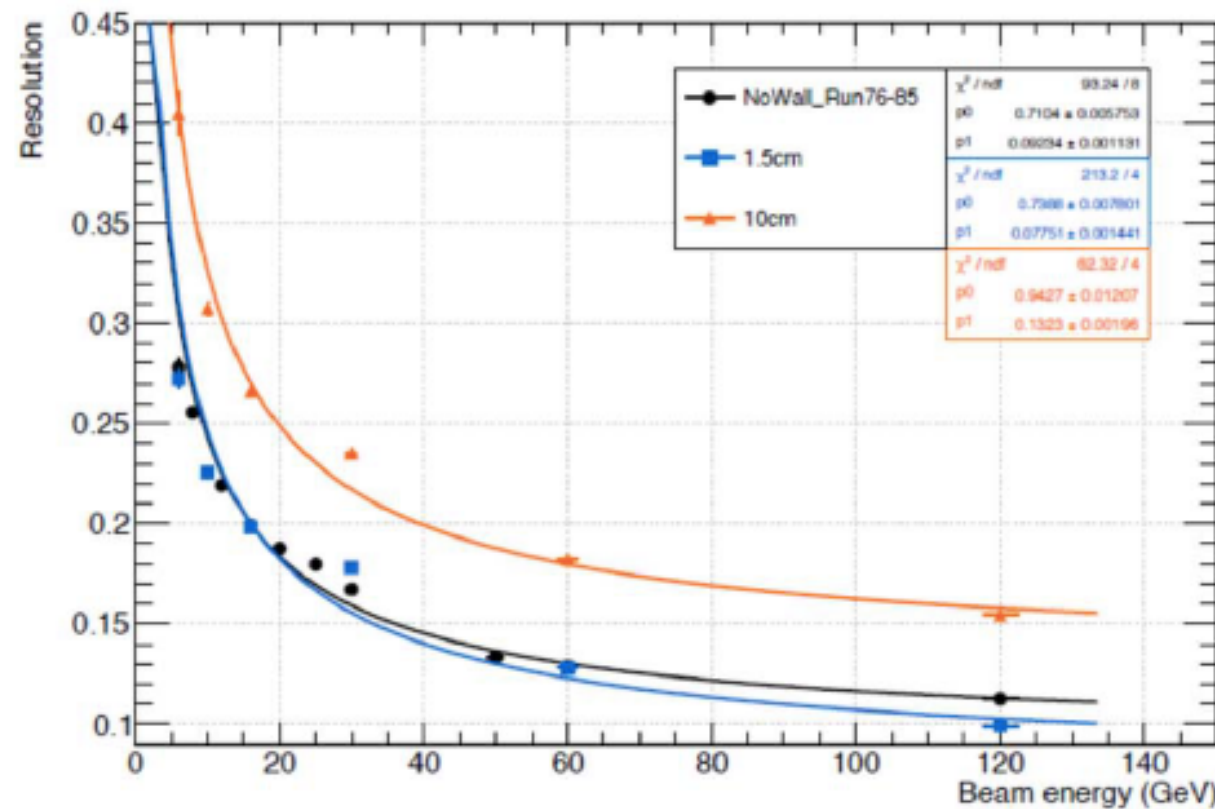

sPHENIX at Electron Ion Collider (EIC)



The National Academies of Sciences, Engineering, and Medicine | THE NATIONAL ACADEMIES PRESS

This PDF is available at <http://nap.edu/25171>

SHARE

An Assessment of U.S.-Based Electron-Ion Collider Science

DETAILS

114 pages | 7 x 10 | PAPERBACK
 ISBN 978-0-309-47856-4 | DOI 10.17226/25171

CONTRIBUTORS

Committee on U.S.-Based Electron-Ion Collider Science Assessment; Board on Physics and Astronomy; Division on Engineering and Physical Sciences; National Academies of Sciences, Engineering, and Medicine

GET THIS BOOK

FIND RELATED TITLES

Visit the National Academies Press at NAP.edu and login or register to get:

- Access to free PDF downloads of thousands of scientific reports
- 10% off the price of print titles
- Email or social media notifications of new titles related to your interests
- Special offers and discounts

Distribution, posting, or copying of this PDF is strictly prohibited without written permission of the National Academies Press. (Request Permission) Unless otherwise indicated, all materials in this PDF are copyrighted by the National Academy of Sciences. Copyright © National Academy of Sciences. All rights reserved.

Timely: US National Academies of Science recommend construction of EIC

Study group (incl. non-sPHENIX members) working on EIC detector design based on sPHENIX

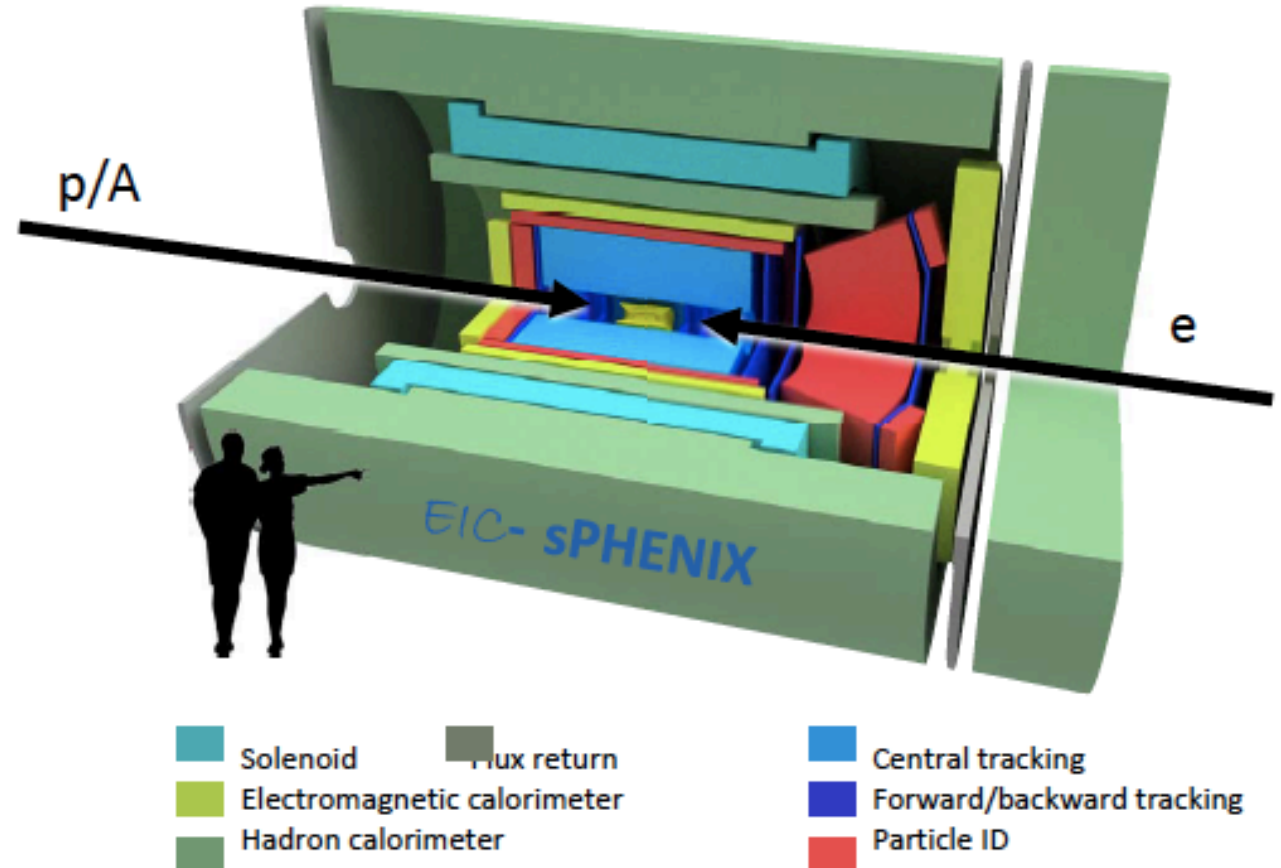

A Day-1 EIC Detector based on sPHENIX

Summary and Outlook



A great opportunity for new collaborators to join the sPHENIX experiment!

Baseline detectors

sPHENIX-note sPH-cQCD-2017-002

Medium-Energy Nuclear Physics Measurements with the sPHENIX Barrel

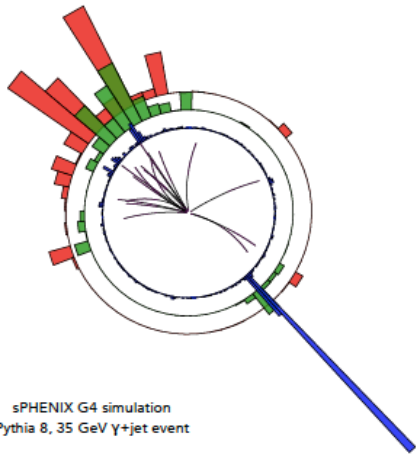

sPHENIX G4 simulation
Pythia 8, 35 GeV Y+jet event

The sPHENIX Collaboration
October 10, 2017

Forward upgrade

sPHENIX-note sPH-cQCD-2017-001

sPHENIX Forward Instrumentation
A Letter of Intent

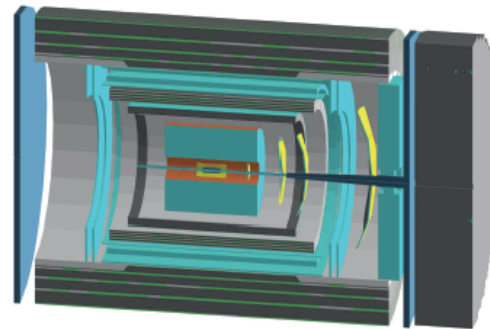

The sPHENIX Collaboration
June 2017

An EIC detector

sPHENIX-note sPH-cQCD-2018-001

An EIC Detector Built Around The sPHENIX Solenoid
A Detector Design Study

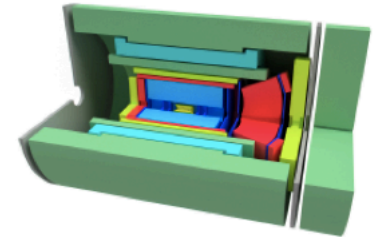

Christine Aldaja, Alexander Bazilevsky, Giorgio Borca-Tasciac, Nils Feige, Enrique Gomez, Yujin Goto, Xiaochun He, Jin Huang, Athira K V, John Lajoie, Gregory Matousek, Kara Mattioli, Pawel Nadel-Turonaki, Cynthia Nunez, Joseph Osborn, Carlos Perez, Ralf Seidel, Desmond Shangase, Paul Stanek, Xu Sun, Jintong Zhang

For the EIC Detector Study Group
and the sPHENIX Collaboration

October 2018

The *Growing* sPHENIX Collaboration

Augustana University
 Banaras Hindu University
 Baruch College, CUNY
 Brookhaven National Laboratory
 China Institute for Atomic Energy
 CEA Saclay
 Central China Normal University
 Chonbuk National University
 Columbia University
 Eötvös University
 Florida State University
 Fudan University
 Georgia State University
 Howard University
 Hungarian sPHENIX Consortium
 Institut de physique nucléaire d'Orsay
 Institute for High Energy Physics, Protvino
 Institute of Nuclear Research, Russian Academy of Sciences, Moscow
 Institute of Physics, University of Tsukuba
 Institute of Modern Physics, China
 Iowa State University
 Japan Atomic Energy Agency
 Joint Czech Group
 Korea University
 Lawrence Berkeley National Laboratory
 Lawrence Livermore National Laboratory
 Lehigh University
 Los Alamos National Laboratory
 Massachusetts Institute of Technology
 Muhlenberg College
 Nara Women's University
 National Research Centre "Kurchatov Institute"
 National Research Nuclear University "MEPhI"
 New Mexico State University

Oak Ridge National Laboratory
 Ohio University
 Peking University
 Petersburg Nuclear Physics Institute
 Purdue University
 Rice University
 RIKEN
 RIKEN BNL Research Center
 Rikkyo University
 Rutgers University
 Saint-Petersburg Polytechnic University
 Shanghai Institute for Applied Physics
 Stony Brook University
 Sun Yat Sen University
 Temple University
 Tokyo Institute of Technology
 Tsinghua University
 Universidad Técnica Federico Santa María
 University of California, Berkeley
 University of California, Los Angeles
 University of California, Riverside
 University of Colorado, Boulder
 University of Debrecen
 University of Houston
 University of Illinois, Urbana-Champaign
 University of Jammu
 University of Maryland
 University of Michigan
 University of New Mexico
 University of Tennessee, Knoxville
 University of Texas, Austin
 University of Tokyo
 University of Science and Technology, China
 Vanderbilt University
 Wayne State University
 Weizmann Institute
 Yale University
 Yonsei University

BNL, June '18



Santa Fe, Dec '17



BNL, June '17



GSU (Atlanta), Dec '16



BNL, June '16



Rutgers, Dec '15



History of RHIC Runs

RHIC is capable of delivering the polarized $n+n/A$ for precision spin CNM physics

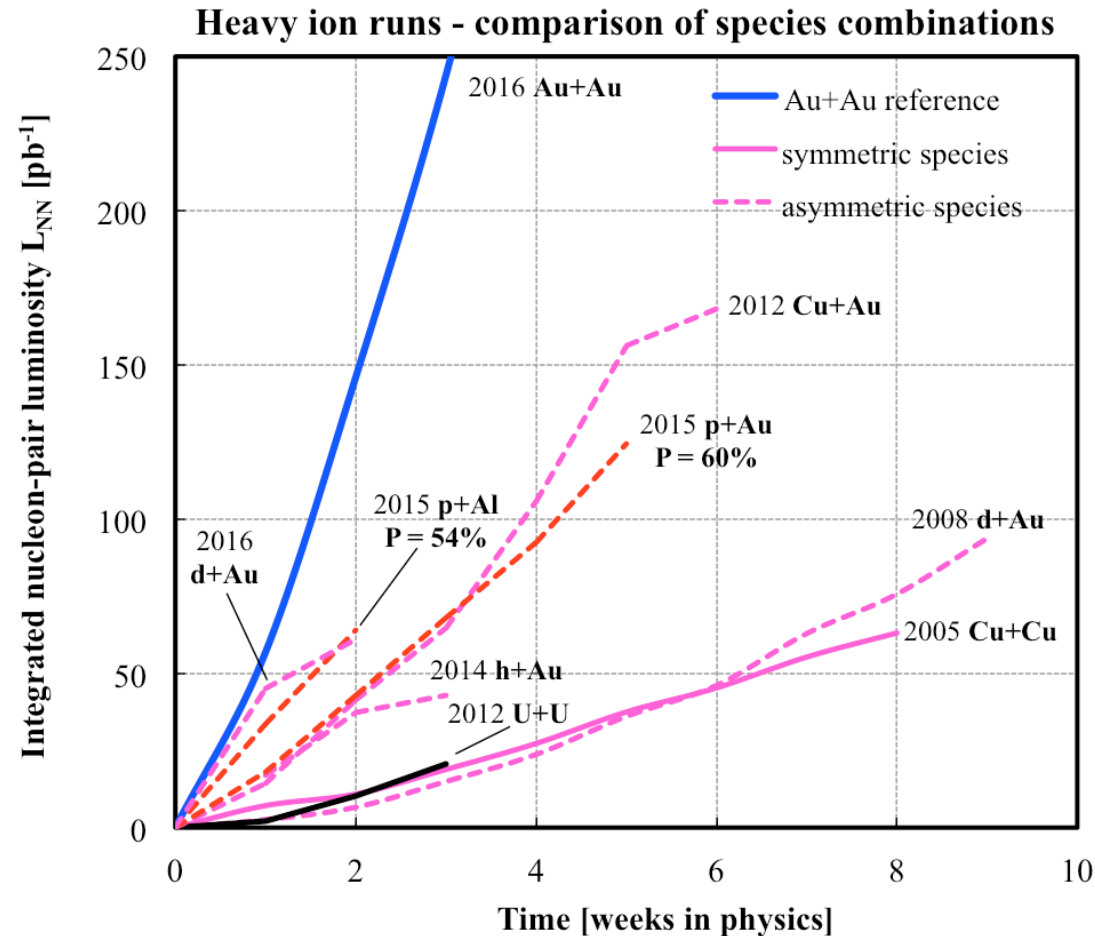
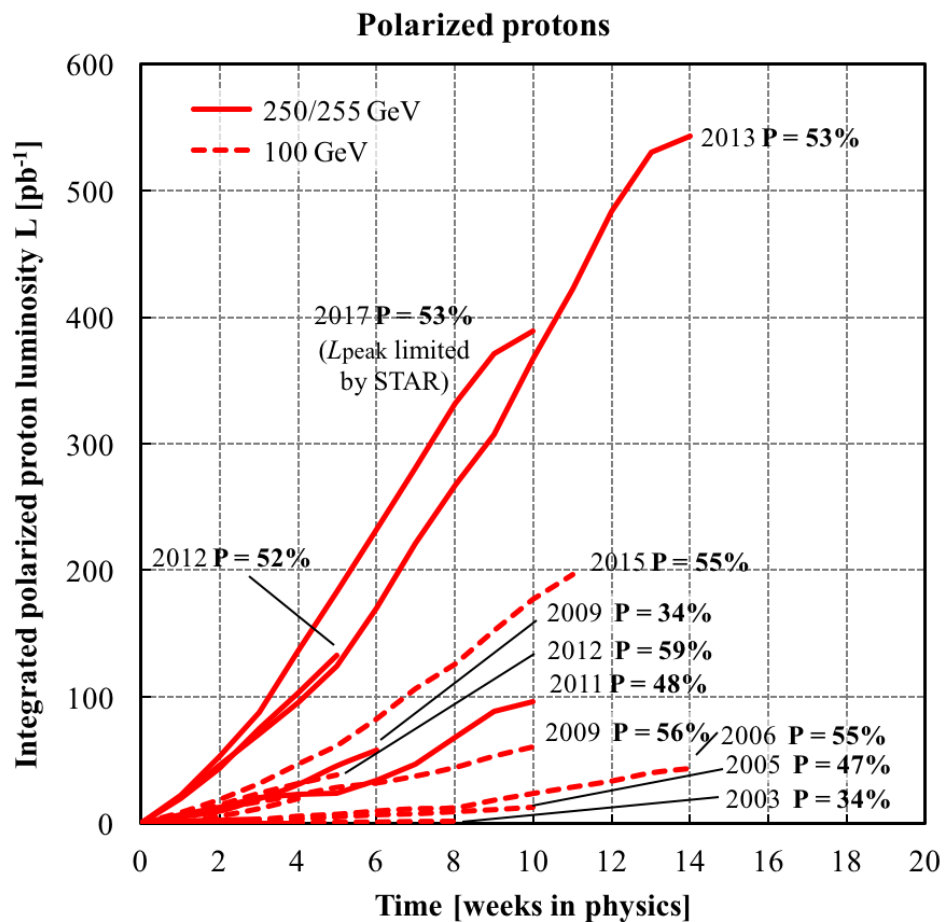

- A very challenging task to deliver polarized p+p, excellent performance from 2012+
- Longitudinally and transversely polarized p+p,
- Transversely polarized p+Au and p+Al, in 2015

History of the Universe

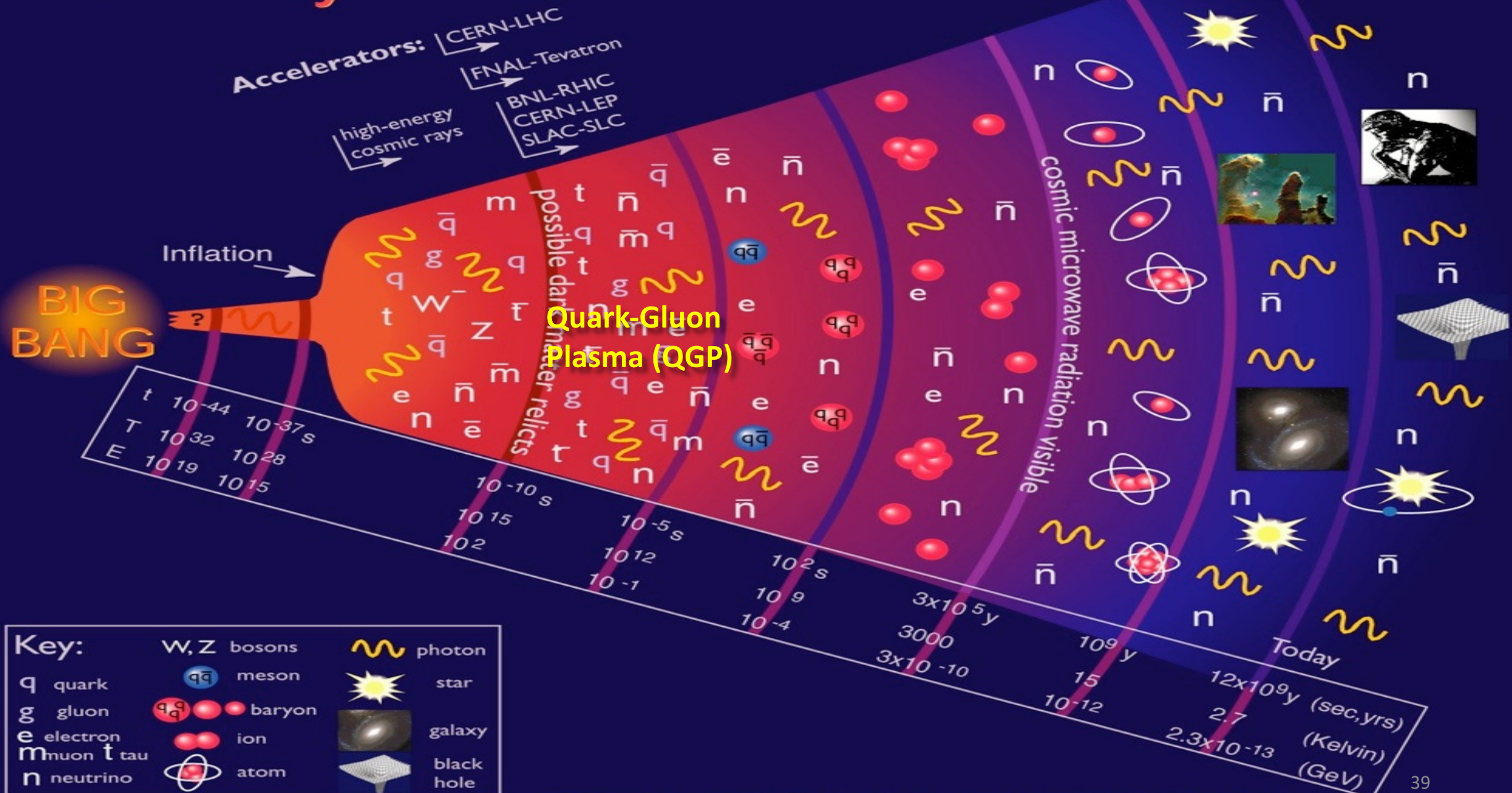

First Transversely Polarized p+A collisions at RHIC

Run15 (2015)

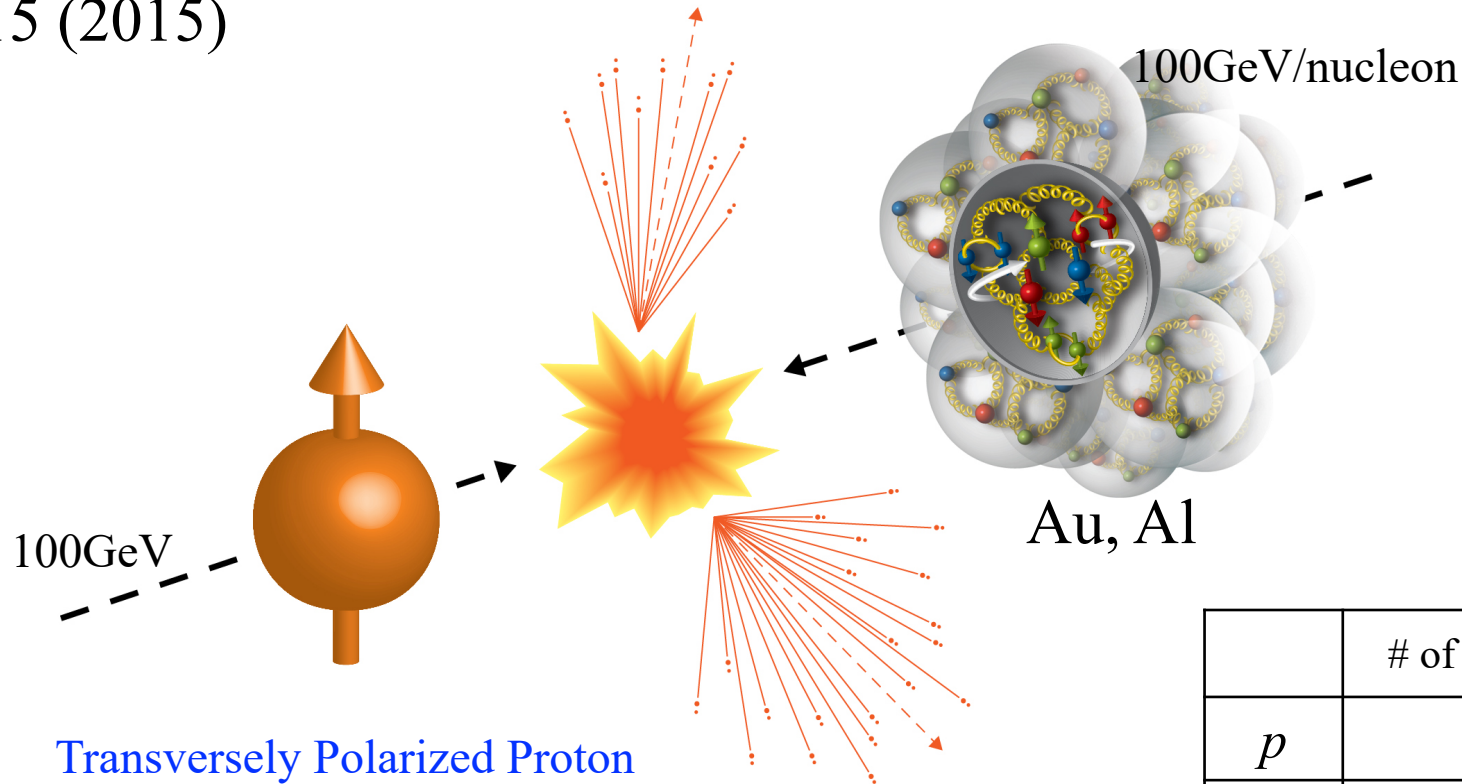

	# of proton	# of neutron
p	1	0
Al	13	14
Au	79	118

sPHENIX: a State of the Art Detector for Heavy Ion Physics at RHIC



CD-0/Science Case
Construction Phase
Ready for Beam

Sept 2016
Jul 2018 -22
Jan 2023

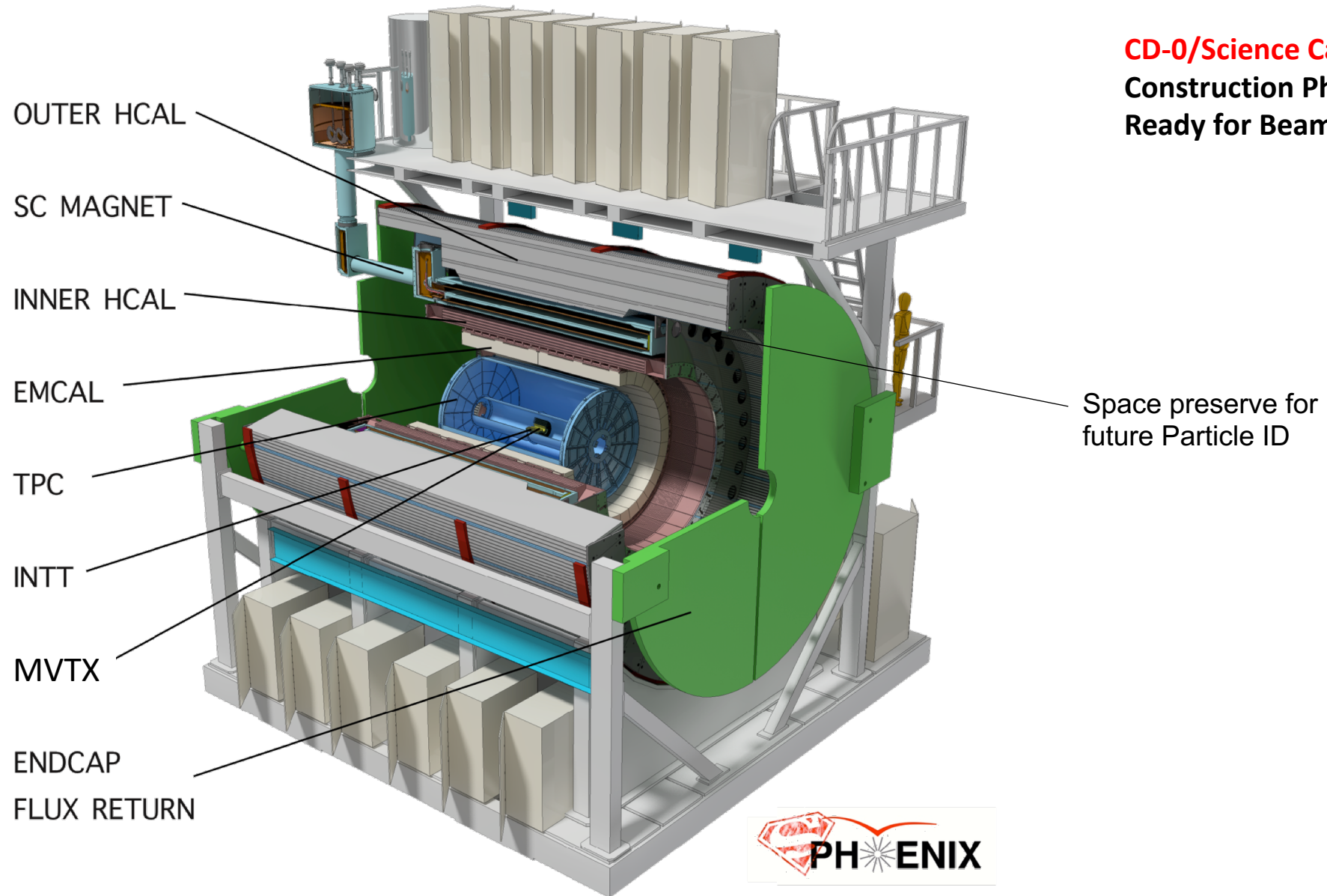

Super conducting magnet

- 1.4 Tesla magnet, $\Phi = 2.8$ m, $L = 3.8$ m Previously used in BaBar @ SLAC
- Moved to BNL in Feb 2015
- Successful cold low field test in 2016
- Full field test in 2018

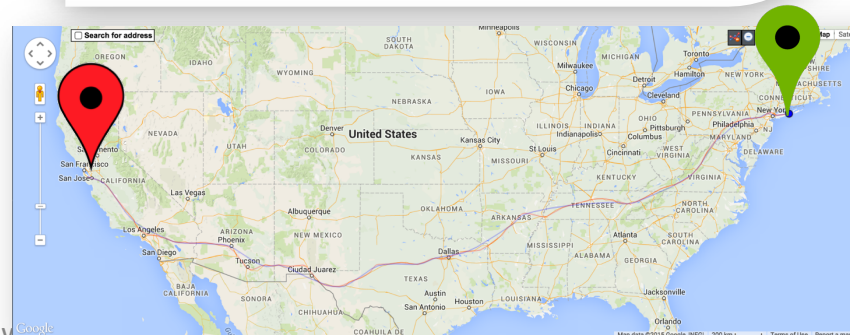
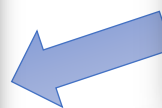

Assembly of EMCal Sector 0



Assembly of Sector 0 at BNL

Sector 0 cooling system

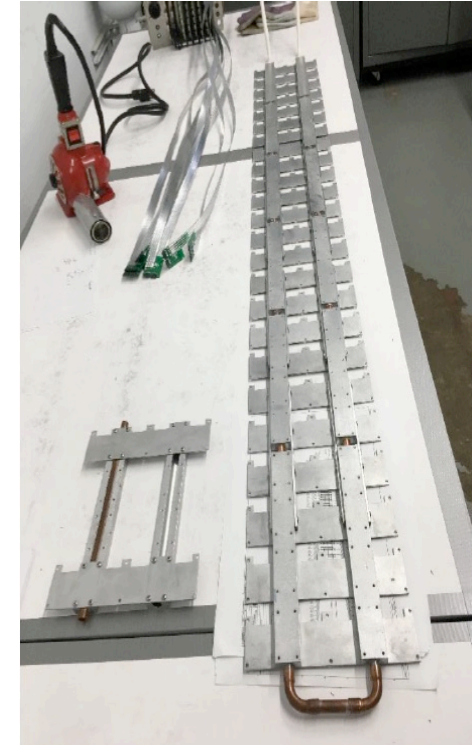
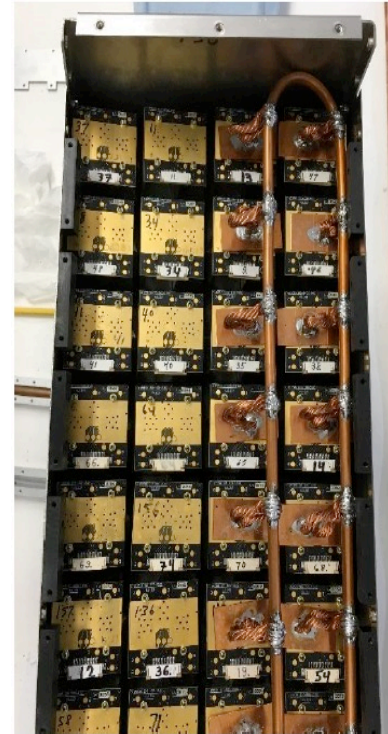

- Sector 0 assembly continues to make good progress at BNL.
- Fit-up of the Sector electronics cooling system underway
- Sector 1 block construction ongoing at UIUC

All 32 Barrel Magnet Steel Sectors at BNL

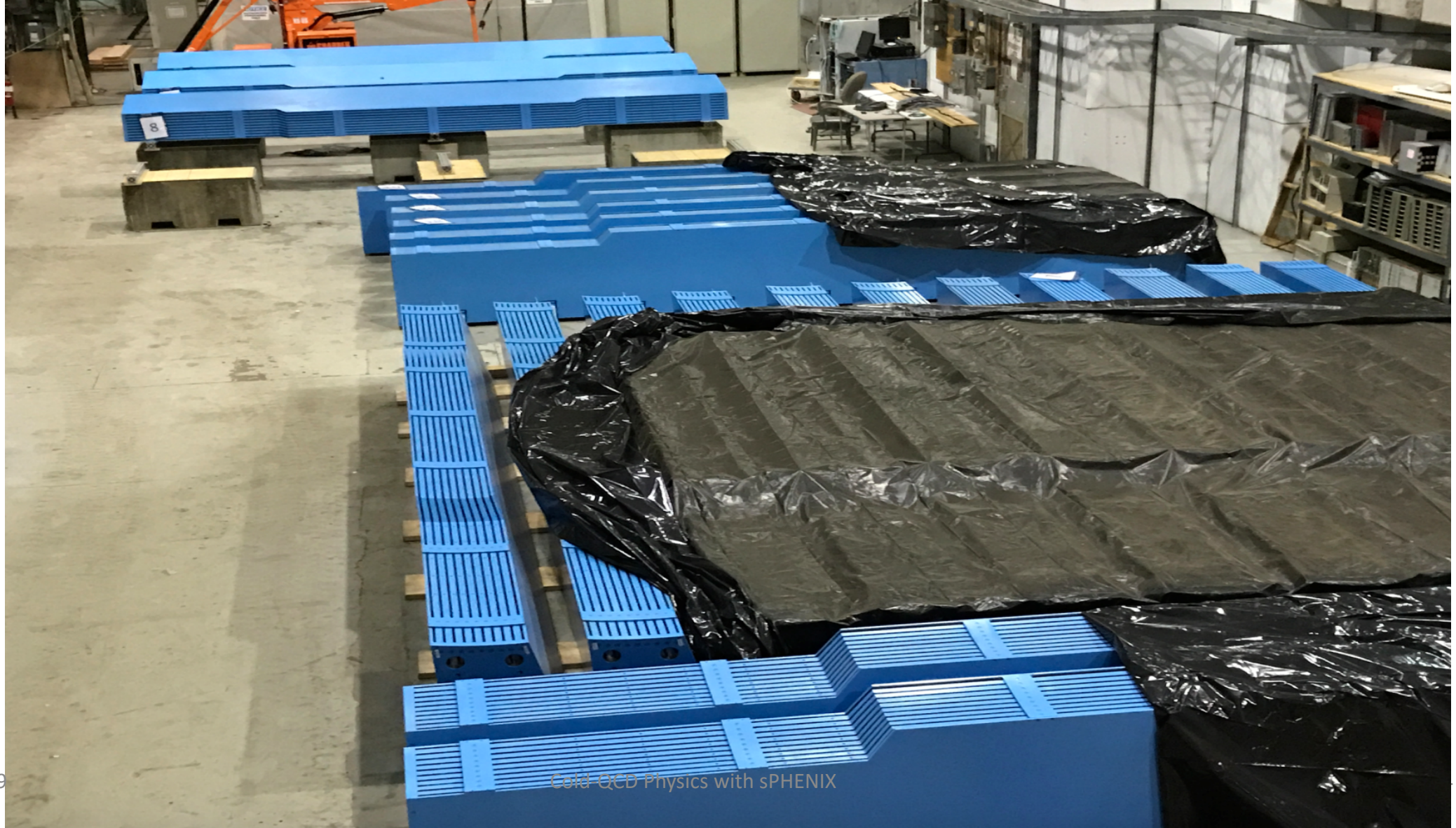

TPC Preproduction Components

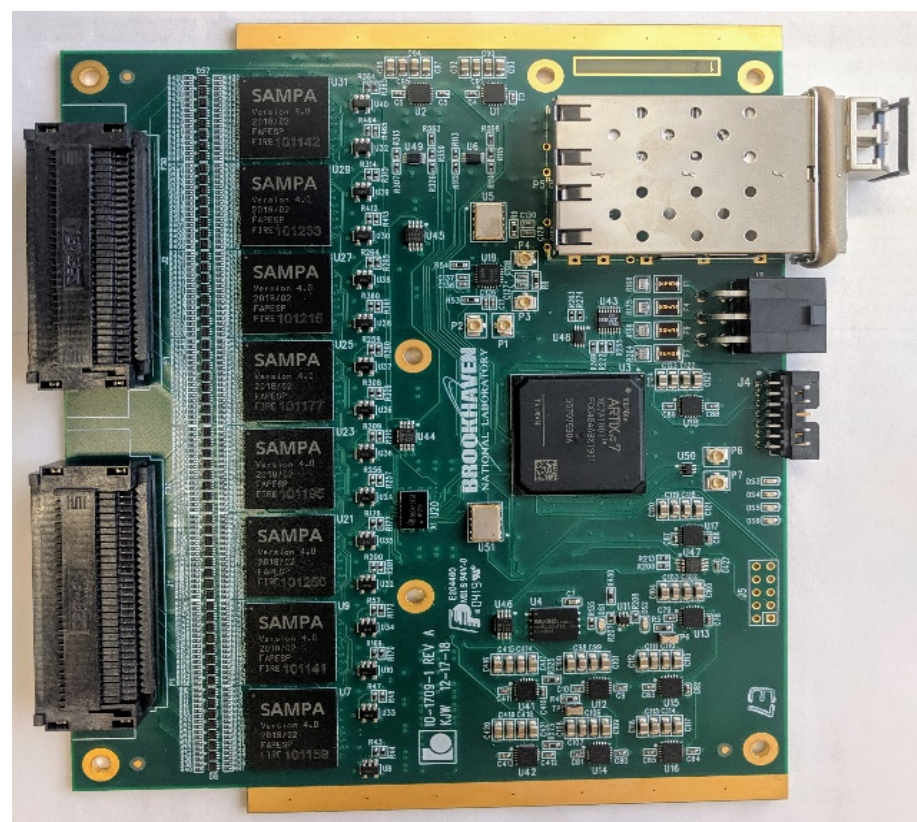
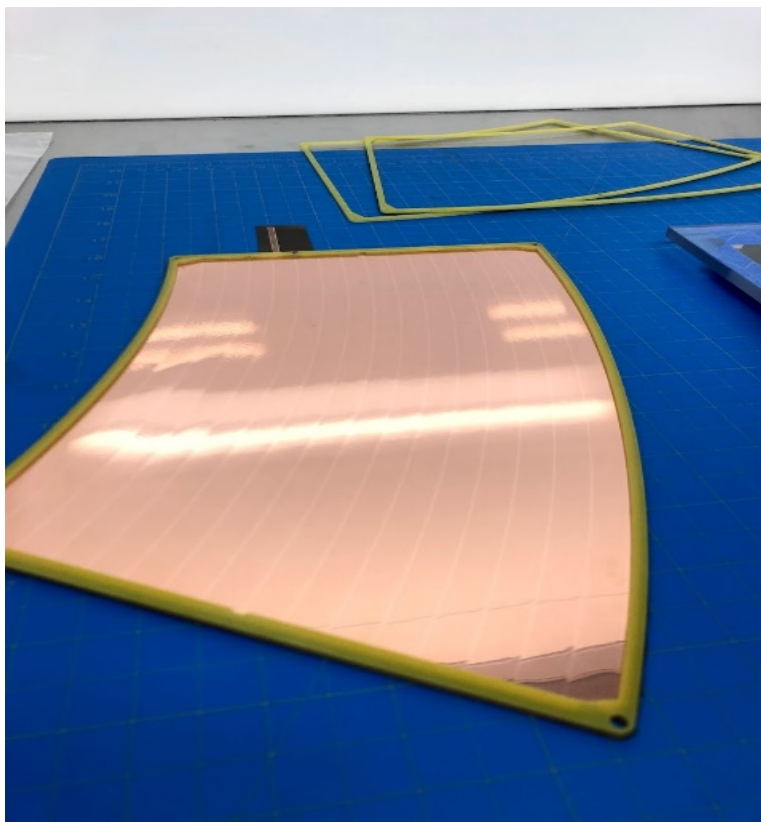

Left: TPC R2 module four-layer GEM stack used in the test beam. **Right:** Preproduction TPC FEE cards carrying eight SAMPA version 4 chips, an Artix-7 FPGA, and double SFP+ links.

sPHENIX 3 Physics Pillars



1. Jets

2. Upsilon

3. Heavy Quarks

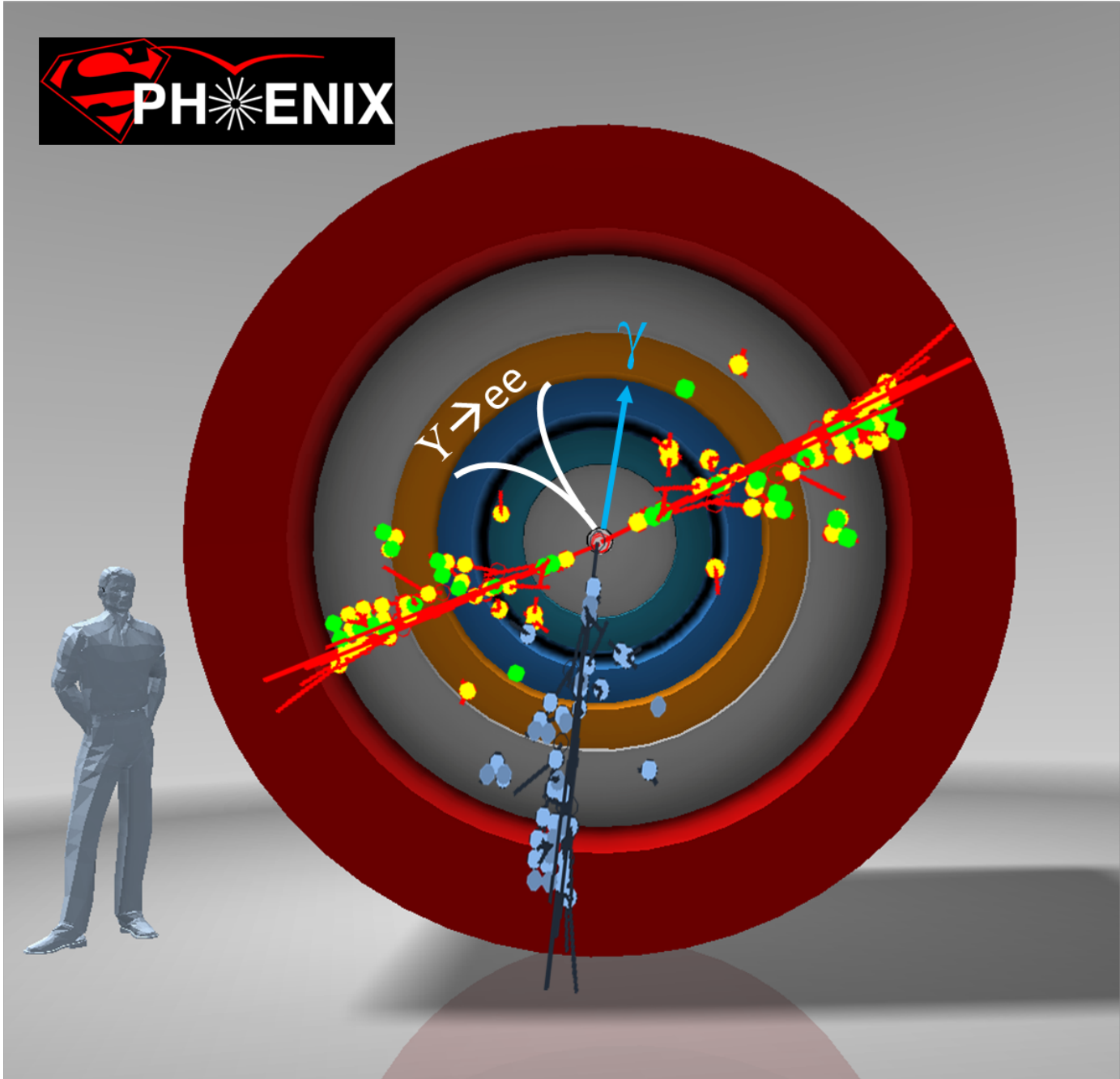

A Broad Physics Program with Jets @sPHENIX



Parton Mass and Flavor Dependence of Jet Suppression and more

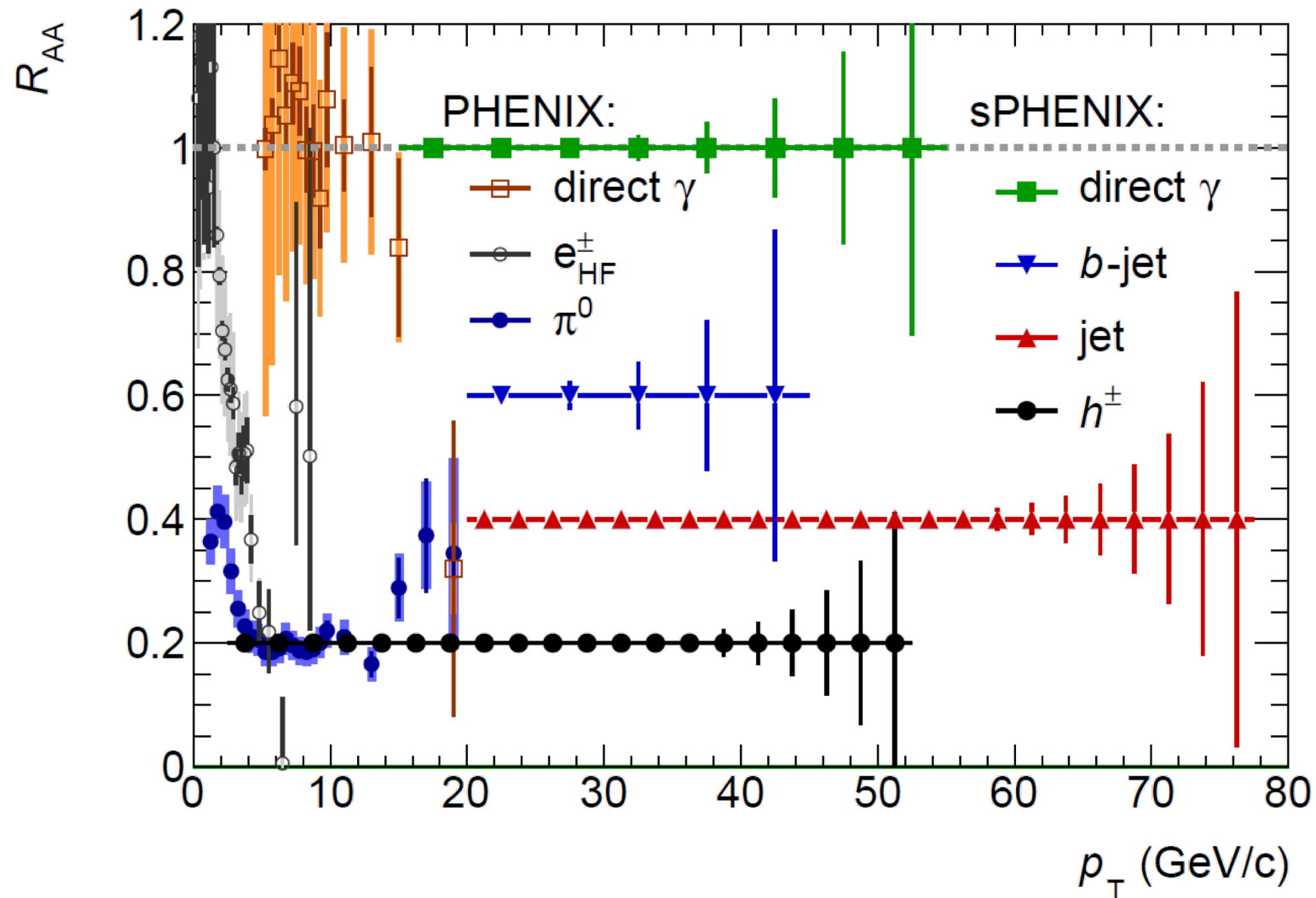

B-jet tagging

- Multi-tracks w/ large DCA
- 2nd vertex mass reco'd

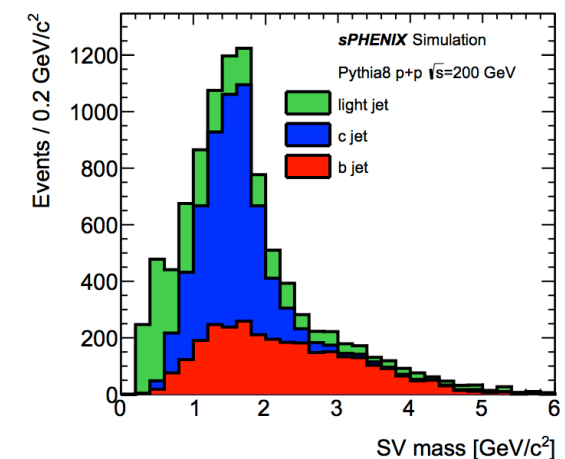
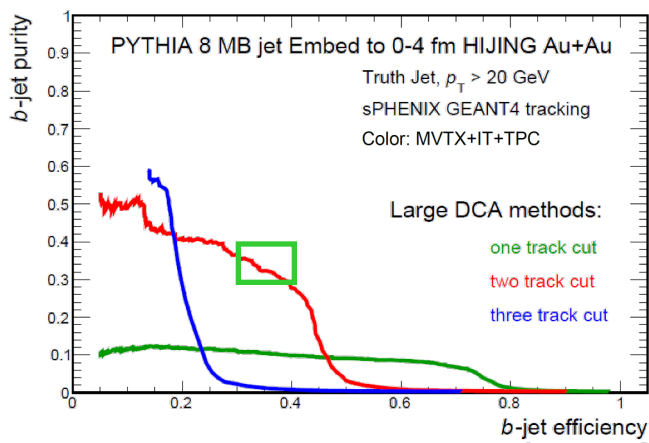
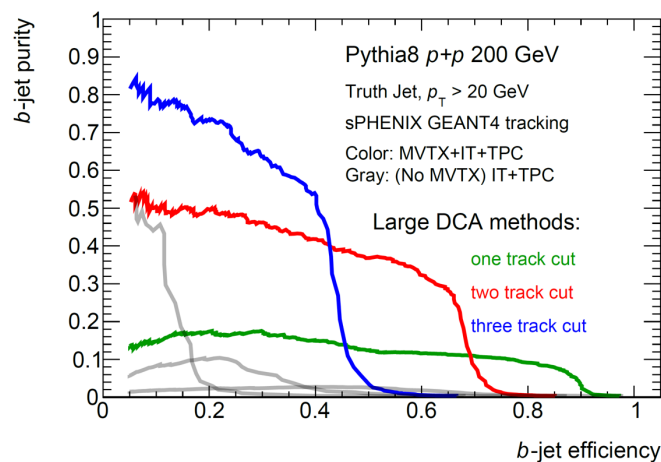
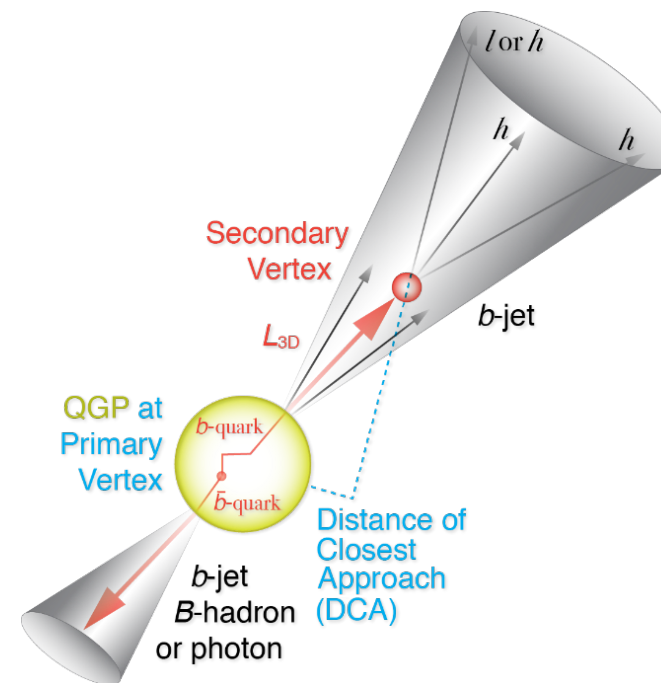

CMS work-point, Phys. Rev. Lett. 113, 132301 (2014)

Toward a Unified Picture of Nucleon Structure

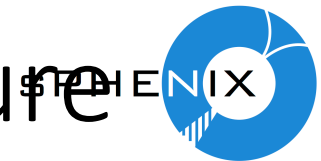

Wigner Distributions

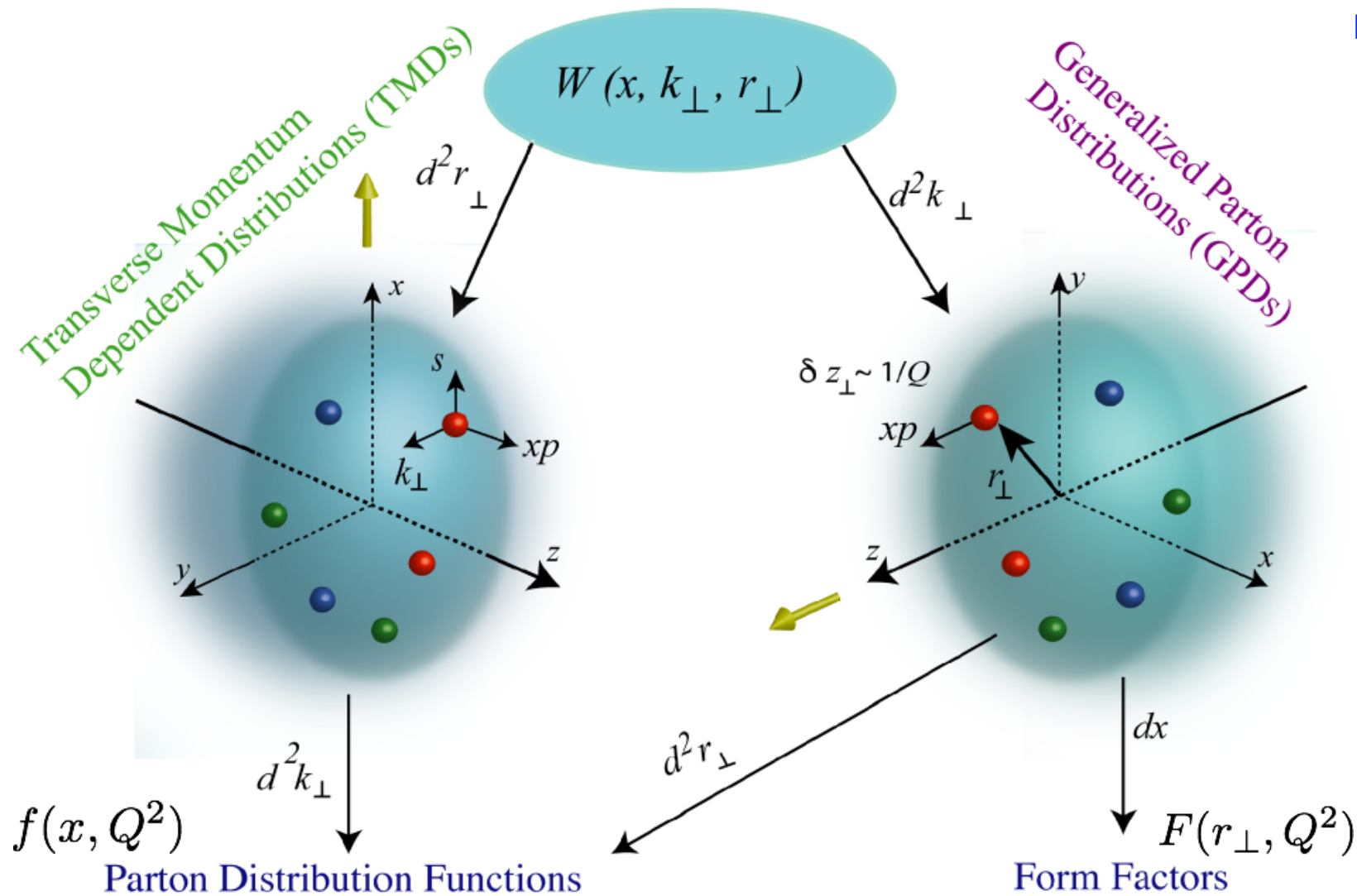

Momentum and Spatial Tomography

Some data, recent progress

Good data, long history

Semi-Inclusive DIS (SIDIS)

In SIDIS, a **hadron** h is detected in **coincidence** with the scattered lepton

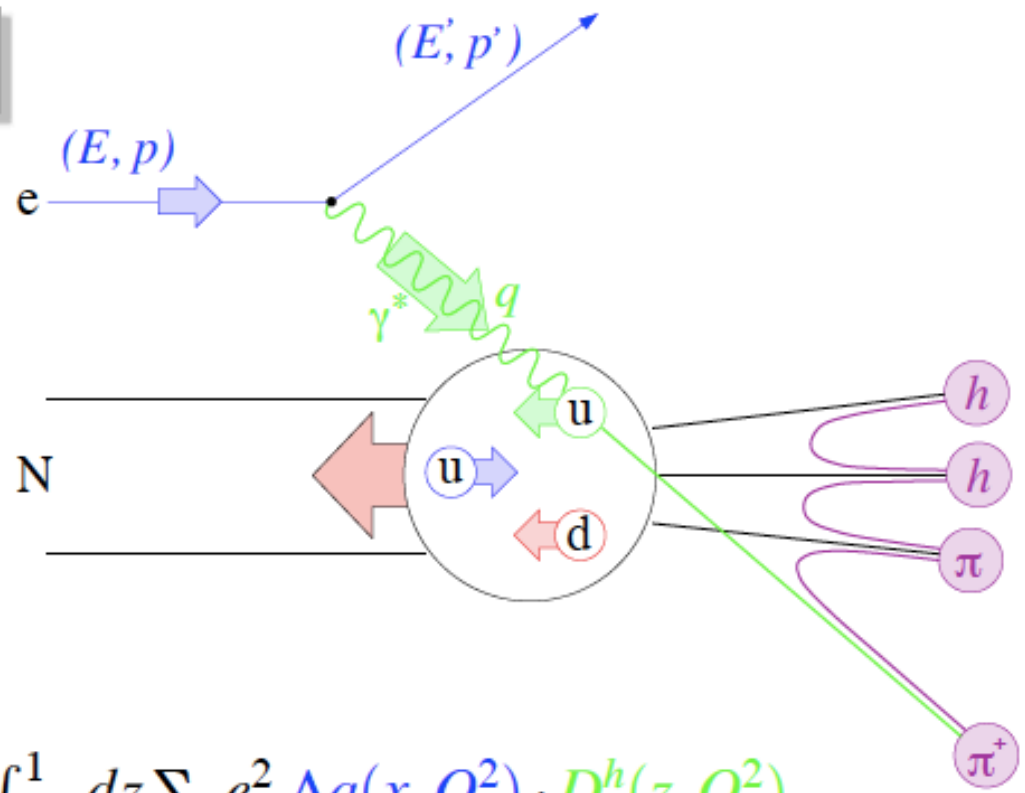

Flavor Tagging
in LO QCD:

$$A_1^h(x, Q^2) = \frac{\int_{z_{min}}^1 dz \sum_q e_q^2 \Delta q(x, Q^2) \cdot D_q^h(z, Q^2)}{\int_{z_{min}}^1 dz \sum_q e_q^2 q(x, Q^2) \cdot D_q^h(z, Q^2)}$$

$D_q^h(z, Q^2)$: **Fragmentation function**

Measures probability for struck quark q to produce a hadron h with

Energy fraction

$$z \equiv \frac{E_h}{\nu}$$